

Model Parallelism in LLM Training

Spring 2026

Lecturer: Yuedong (Steven) Xu

Fudan University

ydxu@fudan.edu.cn

Disclaimer

Machine learning systems is a broad and rapidly evolving field. The course material has been developed using a broad spectrum of resources, including research papers, lecture slides, blogposts, research talks, tutorial videos, and other materials shared by the research community.

Distributed LLM Training: Outline

- Data Parallelism
 - Parameter-Server
 - All-Reduce
 - Memory Optimization
- Model Parallelism
 - **Pipeline Parallelism**
 - Tensor Parallelism
 - Sequence Parallelism
- Mixture of Experts

Pipeline Training

- Retrospect: GPU HBM Content During Training

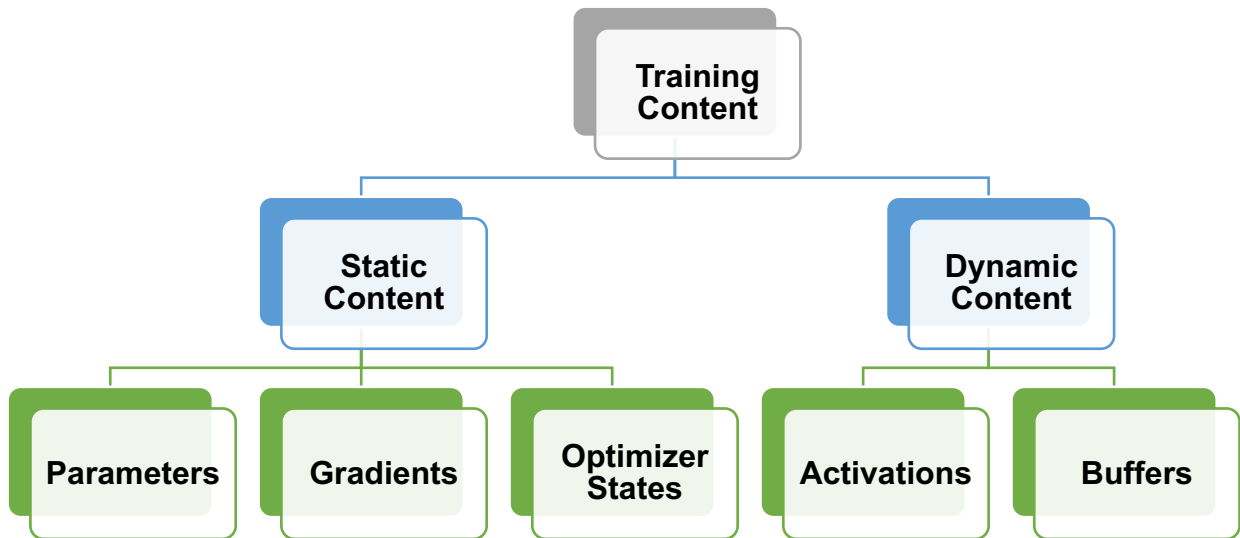

- An example of GPT-3 175B

- **Optimizer States**

- 32-bit Parameter (700 GB)
- Adam Moment (700 GB)
- Adam Variance (700 GB)

- **16-bit Parameter (350 GB)**

- **16-bit Gradient (350 GB)**

- **Activations (depending on batch size)**

- Buffer and Fragmentation

Pipeline Training

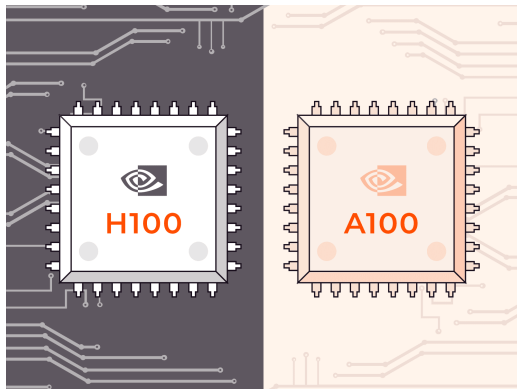

←
Insufficient HBM

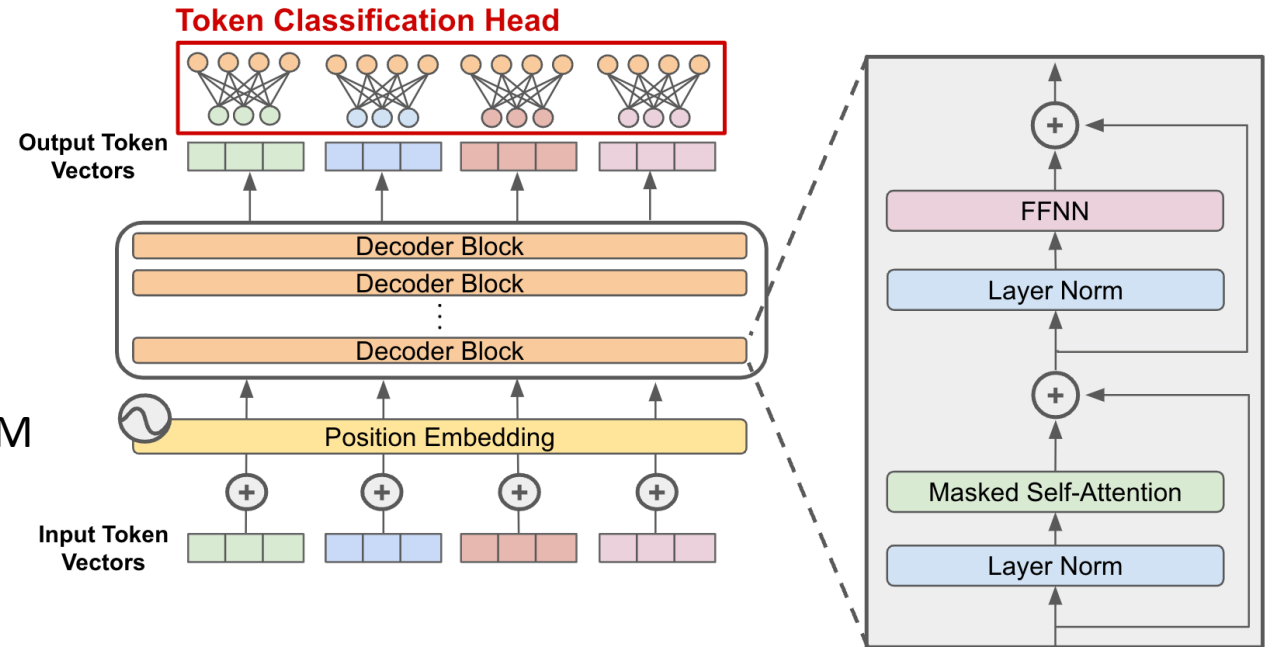

When LLM model is too **LARGE!**

Pipeline Training

- Letting data parallelism be SUFFICIENTLY large
 - Linearly increasing network latency (αn)
 - Inefficient small data chunk transmission
 - Straggler effect caused by any communication pair

Pipeline Training

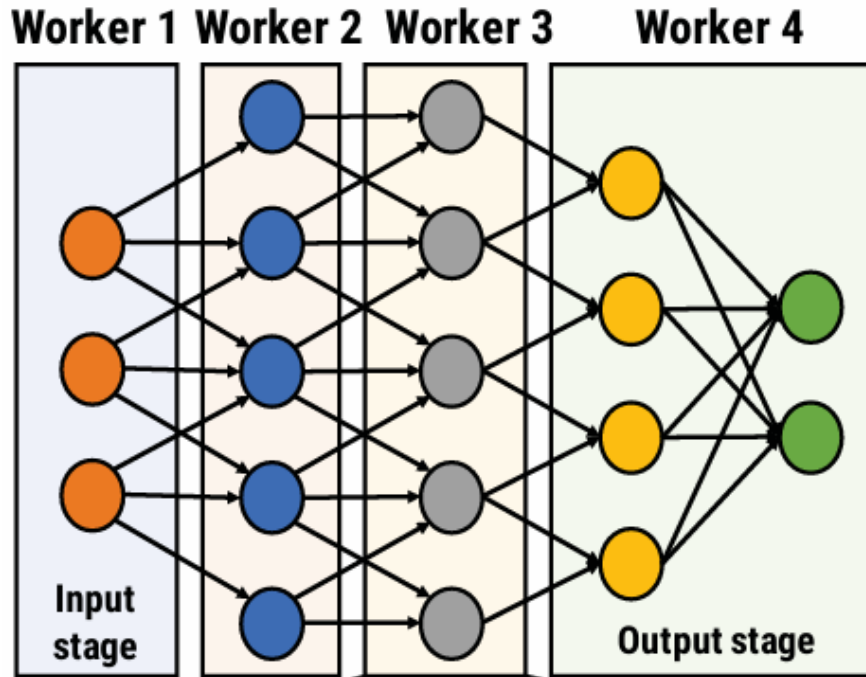

Layerwise partitioning on multiple GPUs

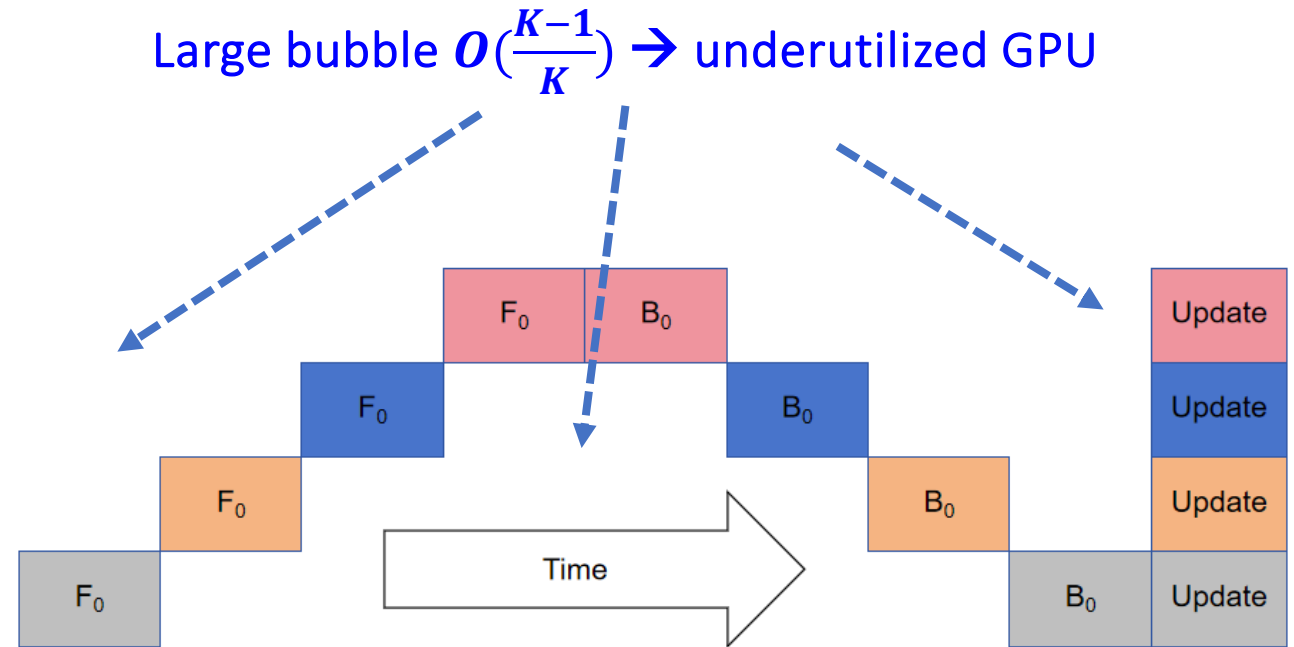

Naïve model parallelism
(F for forward; B for backward)

Pipeline Training

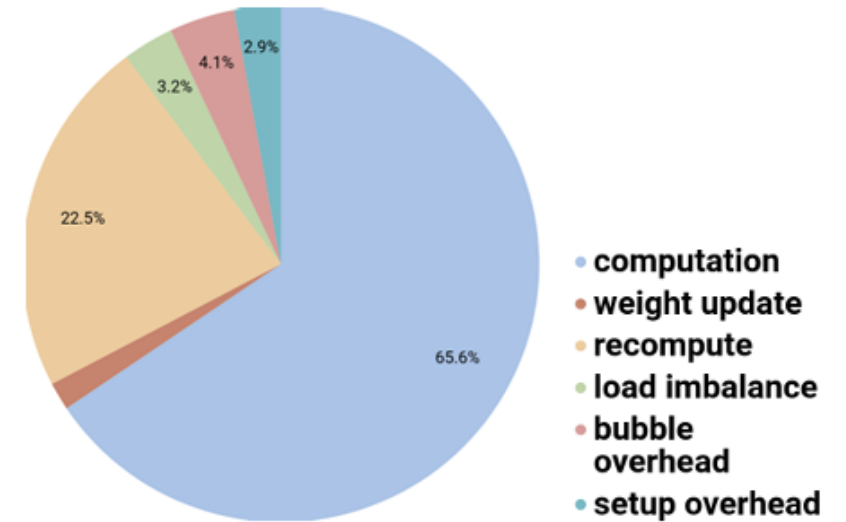
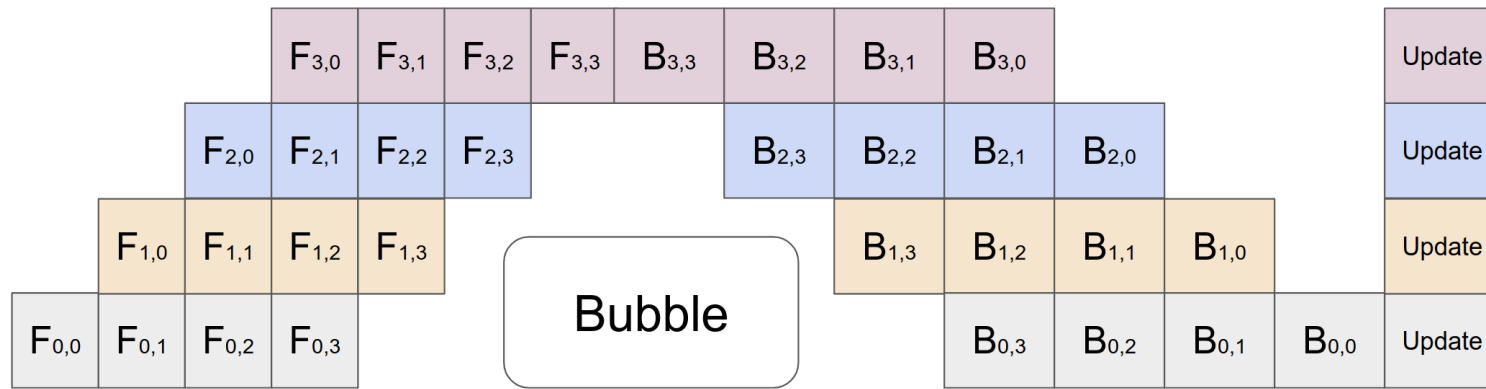

b: batch size

b_m: microbatch size

K: # pipeline stages

M: # microbatches, $b = b_m * M$

Bubble ratio: $O\left(\frac{K-1}{K+M-1}\right)$

Pipeline Training

Cannot be discarded before BP

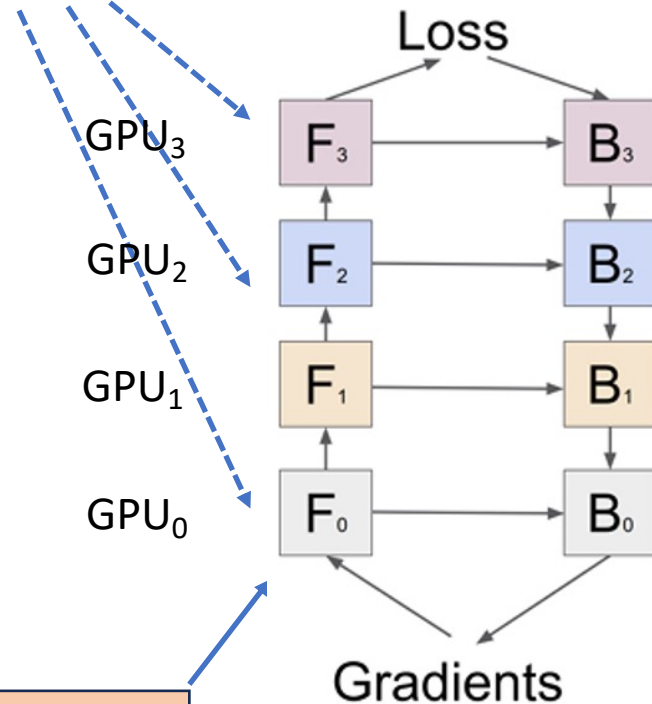

Keep F₀

- Computation time
 - Forward time is half of backward time (why?)
- Communication load
 - Intermediate activation between two partitions
- Memory footprint
 - First stage usually needs more memory: $K * M$
 - Re-materialization (re-computation) Further reducing memory consumption

F-then-B: Forward then Backward

Pipeline Training

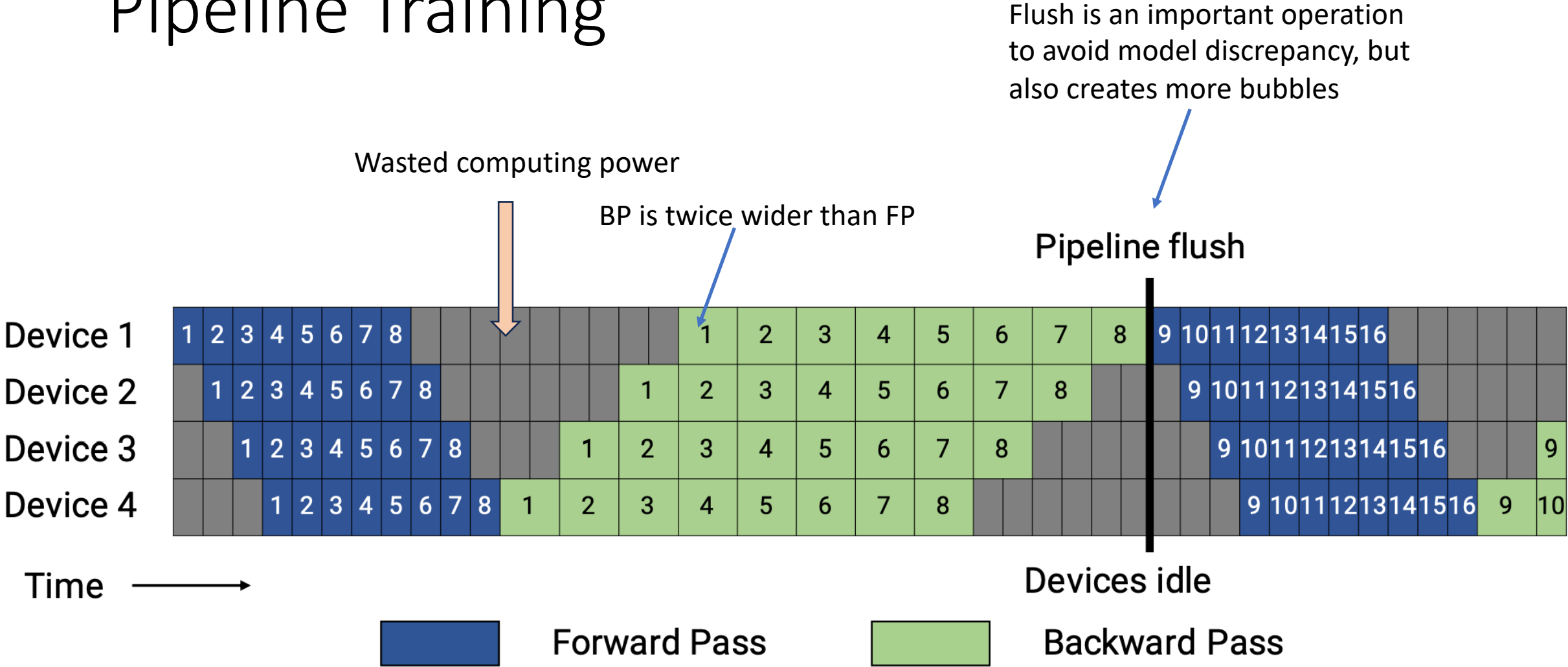

Frequent pipeline flushes lead to increased idle time

Pipeline Training

Orchestrating **execution orders** of forward and backward passes for microbatch so as to reduce bubbles and peak memory footprints?

- Some KEY concepts
 - Synchronous pipeline versus asynchronous pipeline
 - Interleaved versus non-interleaved

Pipeline Training

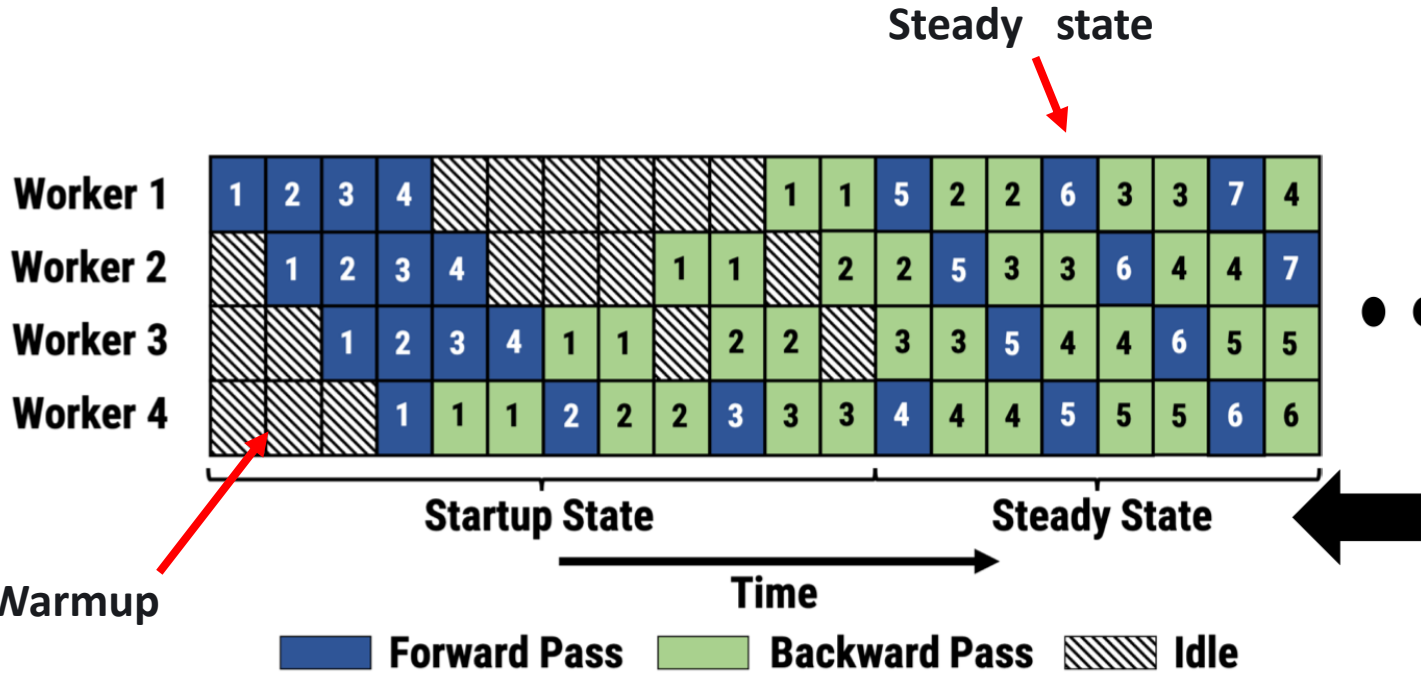

1F1B: One Forward then One Backward

- Minimizing lingering time of activations
 - Immediately executing BP after FP for the first microbatch at the output stage
- At steady state
 - Strictly alternative Forward and Backward operations
- Asynchronous weights

Pipeline Training

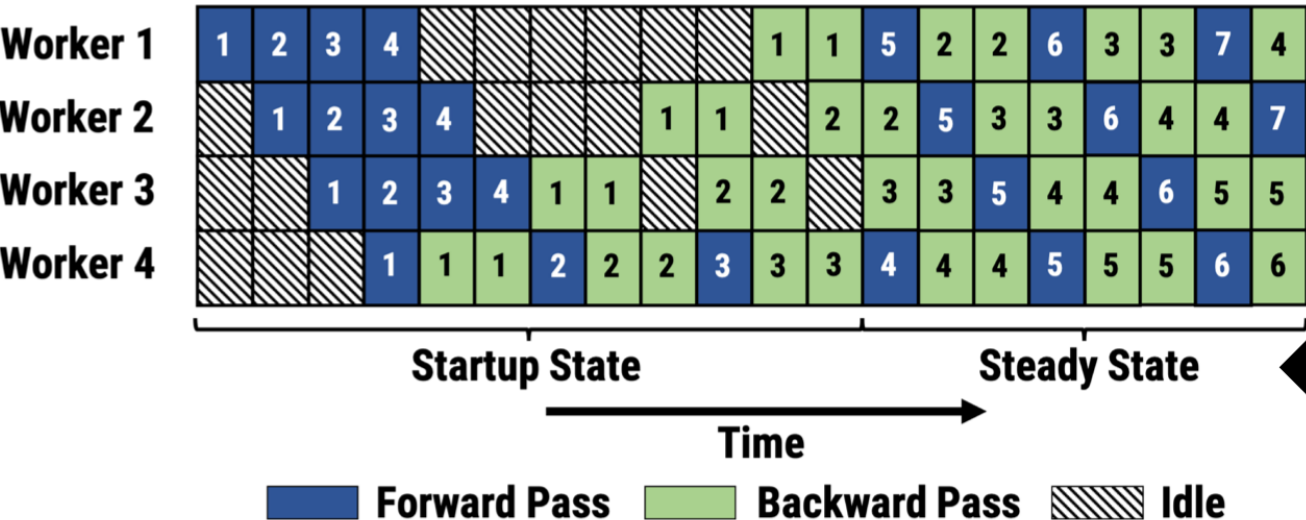

1F1B: One Forward then One Backward

- Challenges
 - How to split a DNN model into different stages?
 - **LOAD BALANCING** across stages
 - How to update parameters? After backward pass, the gradient can be used **immediately to update the parameter**

Pipeline Training

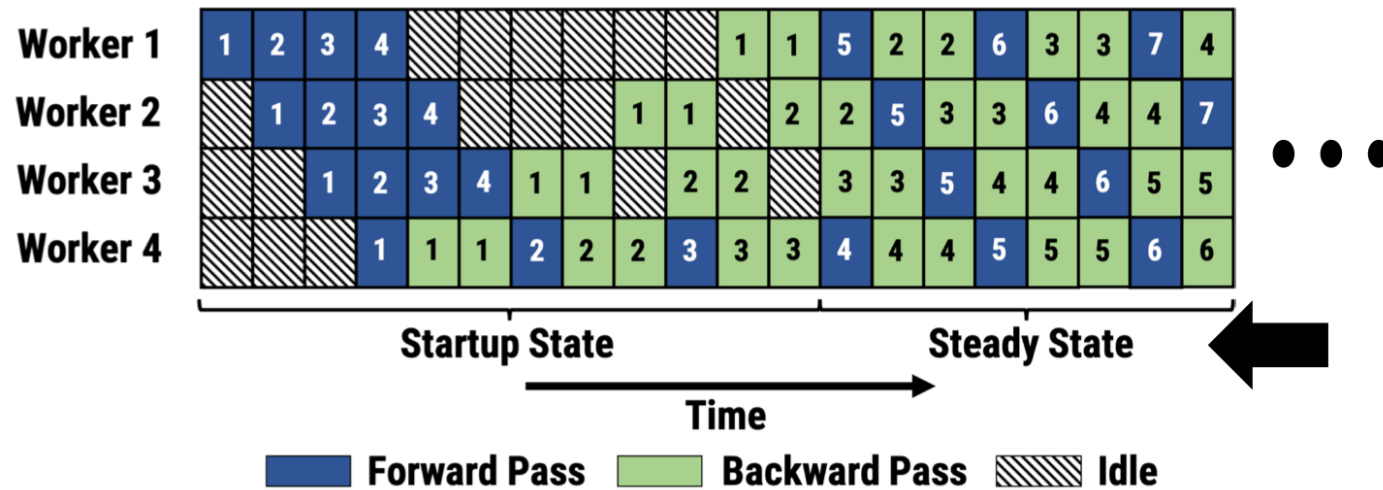

- Observations in stage 1
 - The forward pass of microbatch 5 is performed after the update of **microbatch 1**
 - The backward pass of microbatch 5 is performed after the updates of **microbatches 2, 3 and 4**

Forward and backward passes operate on different versions of parameters!

(Extended Learning)

Subscript: stage ID, superscript: model version ID

Pipeline Training

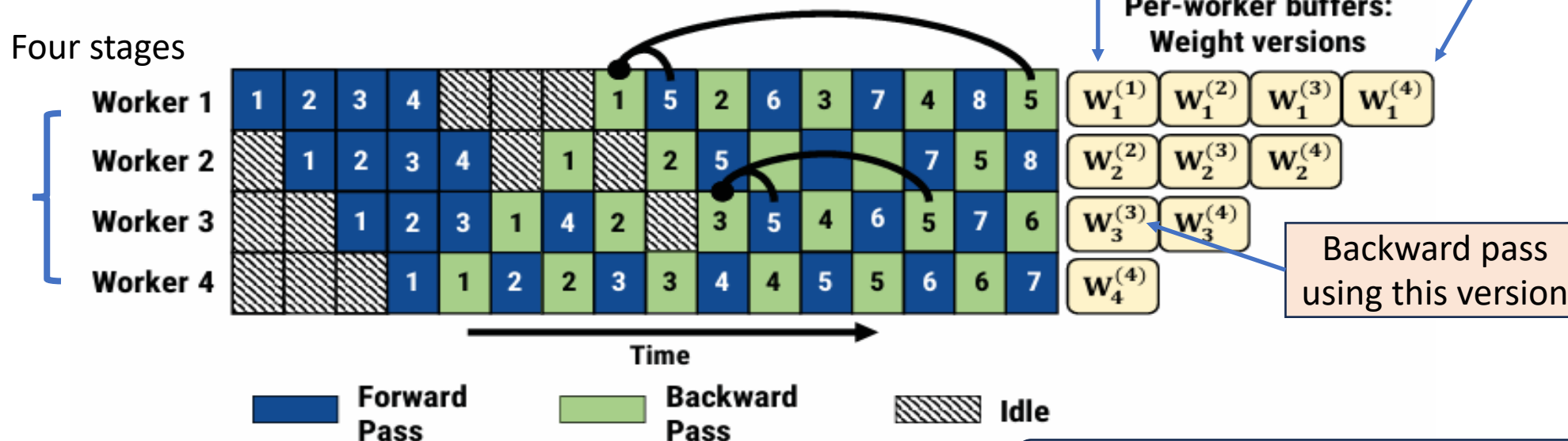

No guarantees across stages!

- **Weight stashing** of PipeDream

- Keeps multiple versions of model weights—one for each active minibatch.
- Forward pass: each pipeline stage uses the most recent weight version available. Once the forward pass for a minibatch is completed, the corresponding weight version is stored.
- Backward pass: the same version is reused to compute gradients and update weights, ensuring that both passes for a given minibatch use identical parameters within a stage.

Pipeline Training

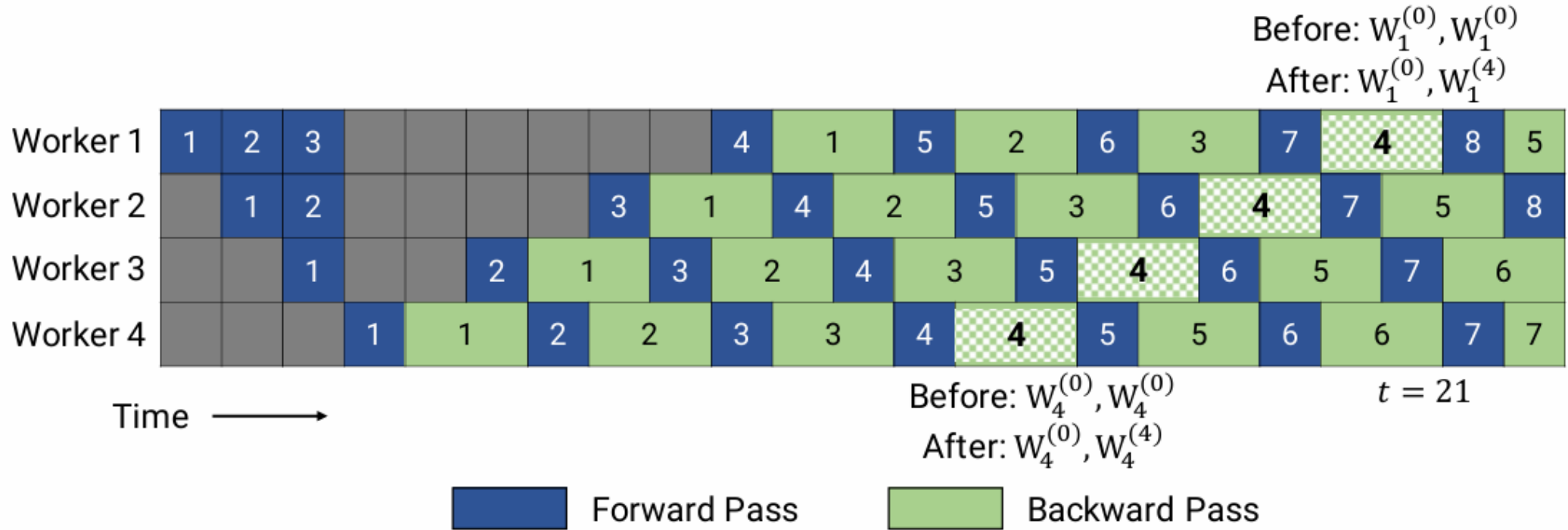

PipeDream-2BW:

- less frequent flushing than Gpipe
- keeping no more than two model versions.

Think why? How does it relate to pipeline depth K and number of microbranches M

(Extended Learning)

Pipeline Training



- Flushing causes more bubbles
 - Warmup + Colddown
- Flushing needs less memory

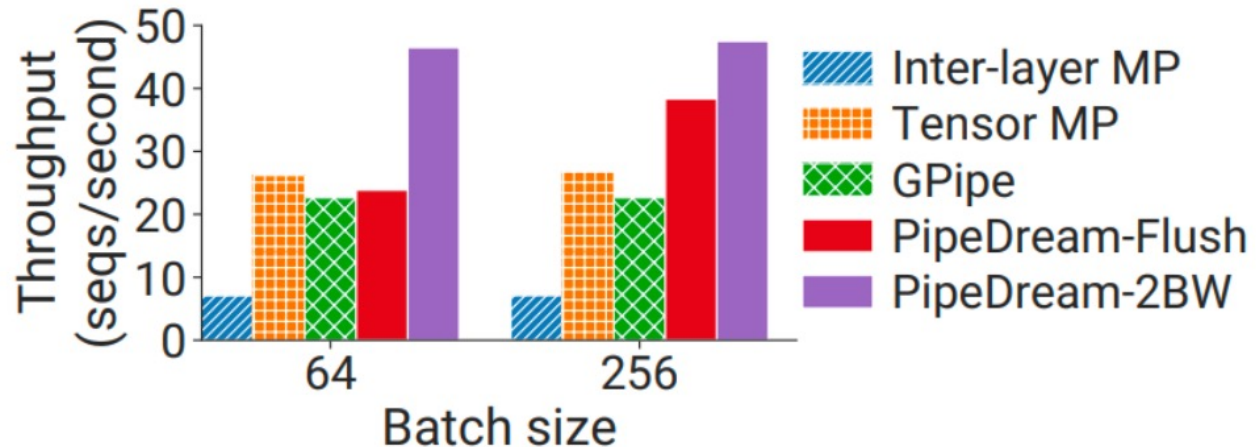

- Training BERT 2.2B with 8-way model parallelism (8 V100 GPU)
- PipeDream is much better than vanilla GPipe

Pipeline Training

- IFIB integrated in Megatron-LM later on



Assign multiple stages to each device

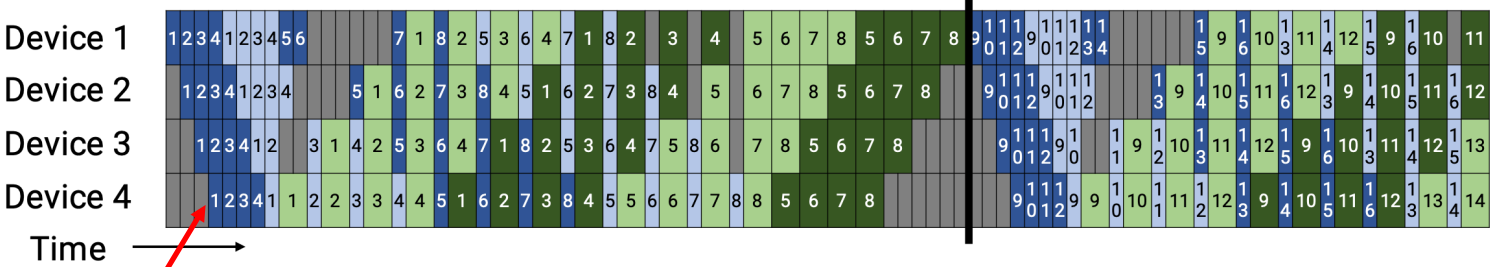

Forward Pass Backward Pass

Interleaved 1F1B

(Stages: 4, Layers: 16, each device assigned with 2 chunks. Layer 0-1, 8-9 on Device 1; Layer 2-3,10-11 on Device 2; Layer 4-5, 12-13 on Device 3 and Layer 6-7, 14-15 on Device4)

- Key ides:
 - Further dividing each microbatch into even smaller chunks
 - Microbatch and small chunks execute alternatively
- Advantages/disadvantages
 - Smaller bubble
 - Higher inter-state traffic load

Pipeline Training

- IFIB integrated in Megatron-LM later on

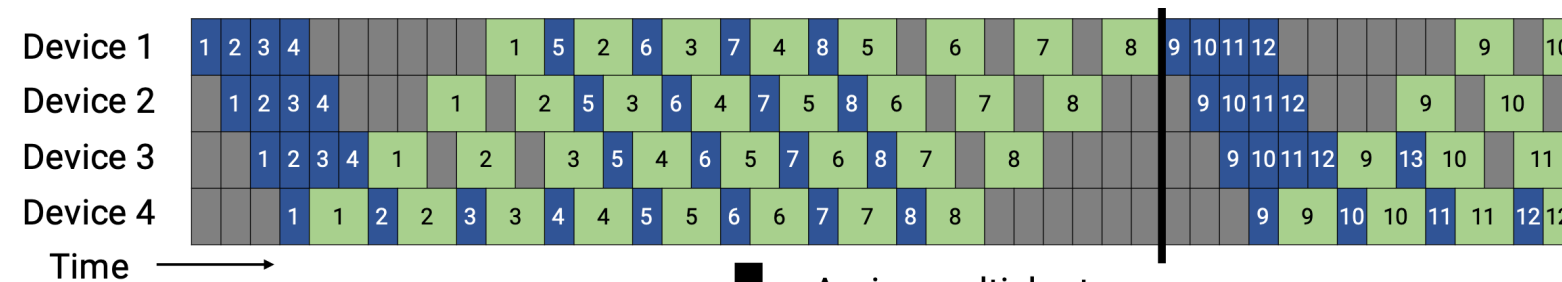

Assign multiple stages to each device

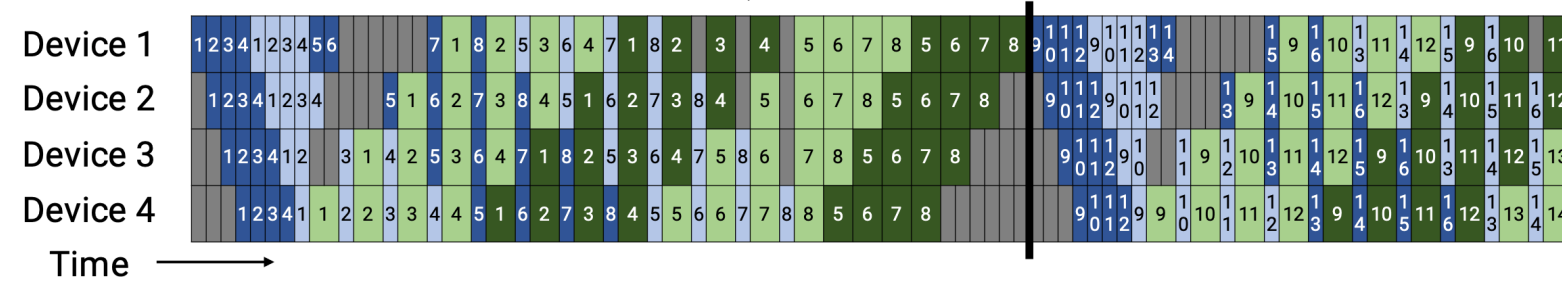

Forward Pass
 Backward Pass

- Model placement:
 - Stages: 4, Layers: 16, each device assigned with 2 chunks
 - Layer 0-1, 8-9 on Device 1
 - Layer 2-3, 10-11 on Device 2
 - Layer 4-5, 12-13 on Device 3
 - Layer 6-7, 14-15 on Device 4

Be aware of the communication scheduling!

Pipeline Training

- A microscopic view of BP

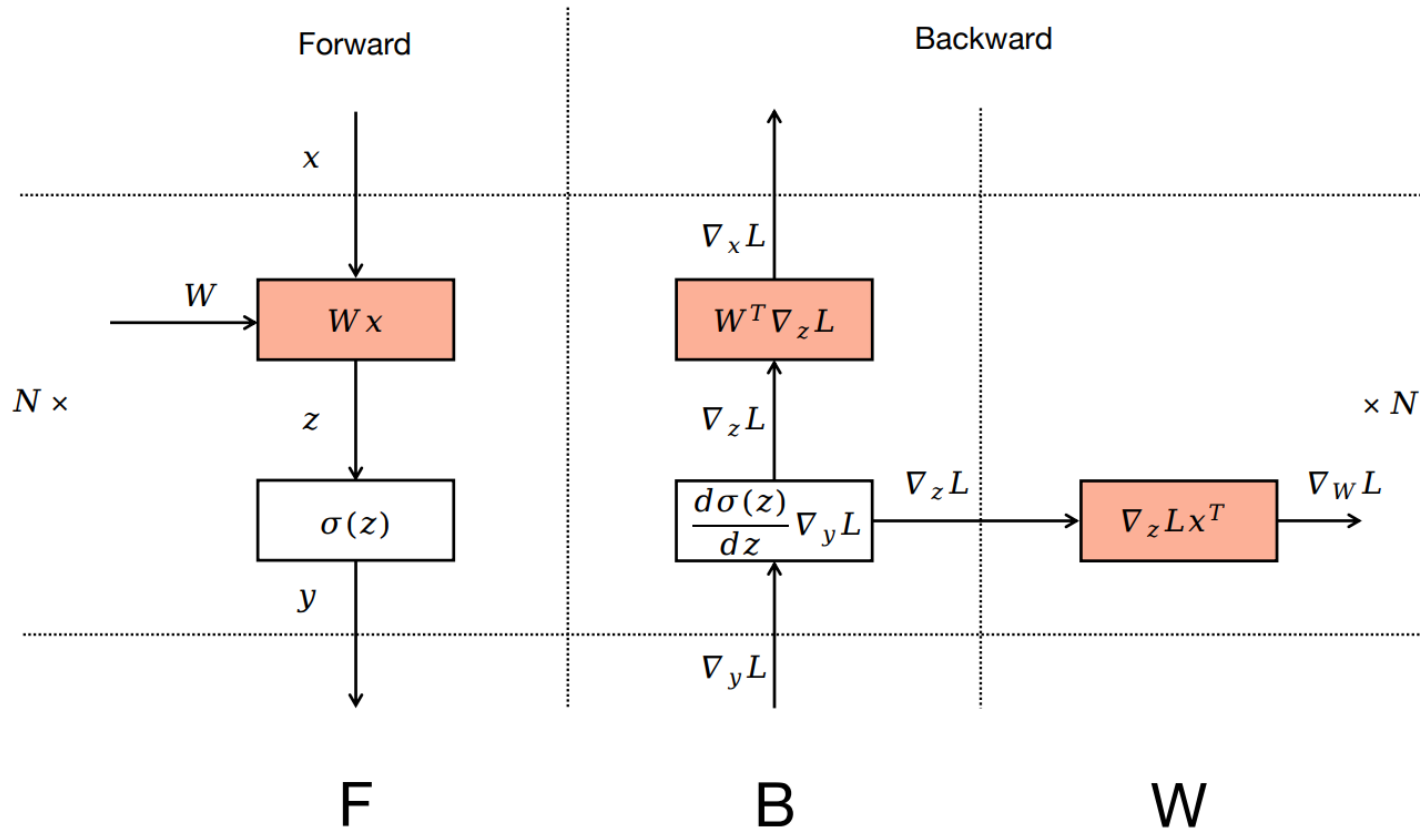

- Derivative over input
 - for backward propagation
- Derivative over weight
 - for updating model directly
- $\nabla_W f(\mathbf{x}, \mathbf{W})^\top \frac{dl}{dy}$
computed immediately after $\nabla_x f(\mathbf{x}, \mathbf{W})^\top \frac{dl}{dy}$

Pipeline Training

- A microscopic view of BP

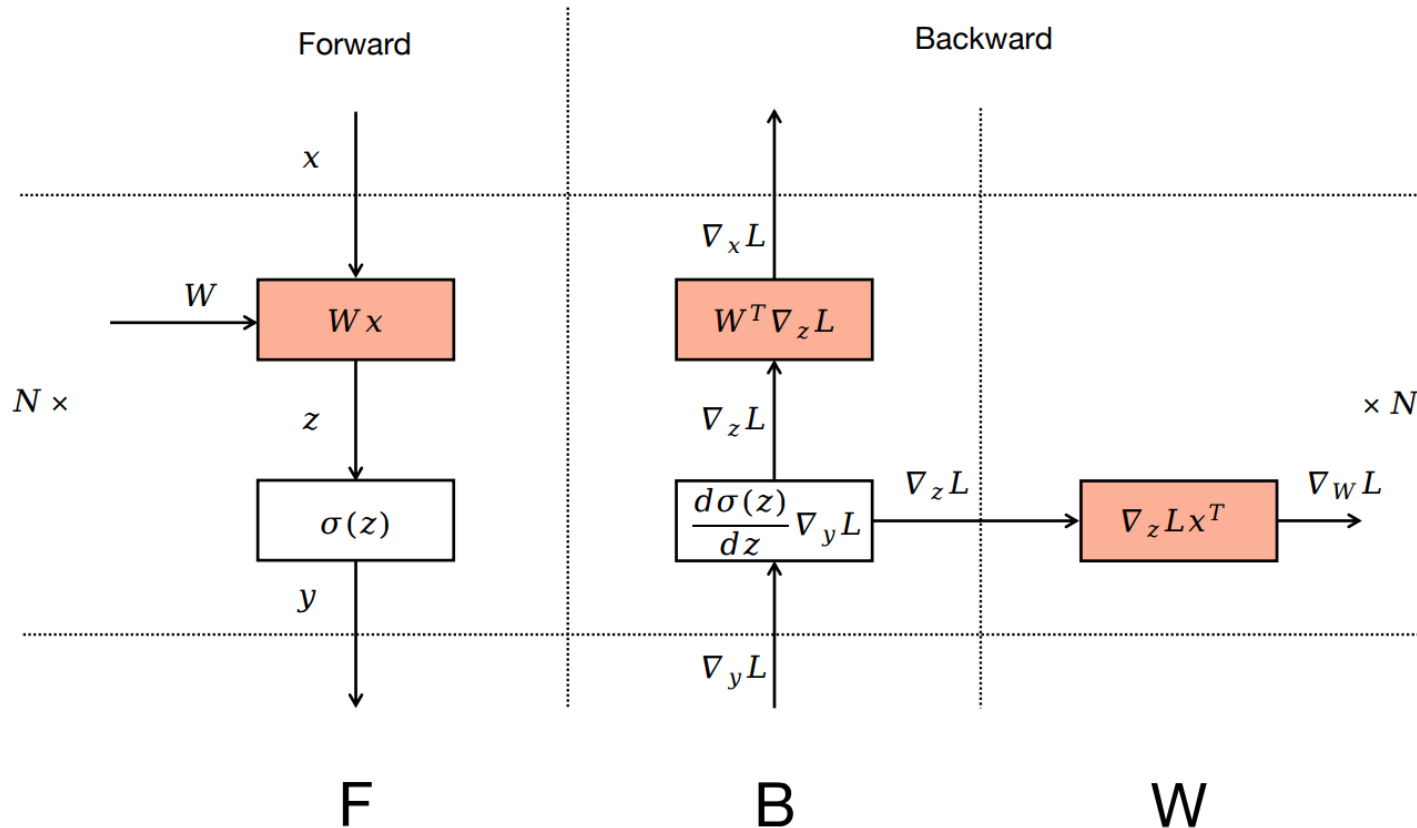

- Question
 - Which one should be computed first in the pipeline?

$$\nabla_x f(\mathbf{x}, \mathbf{W})^\top \frac{dl}{dy}$$

or

$$\nabla_W f(\mathbf{x}, \mathbf{W})^\top \frac{dl}{dy}$$

Distributed LLM Training: Outline

- Data Parallelism
 - Parameter-Server
 - All-Reduce
 - Memory Optimization
- Model Parallelism
 - Pipeline Parallelism
 - **Tensor Parallelism**
 - Sequence Parallelism
- Mixture of Experts

Tensor Parallelism

- A visual perception of TP

Transformers

"Pre-Layernorm" Transformer Block

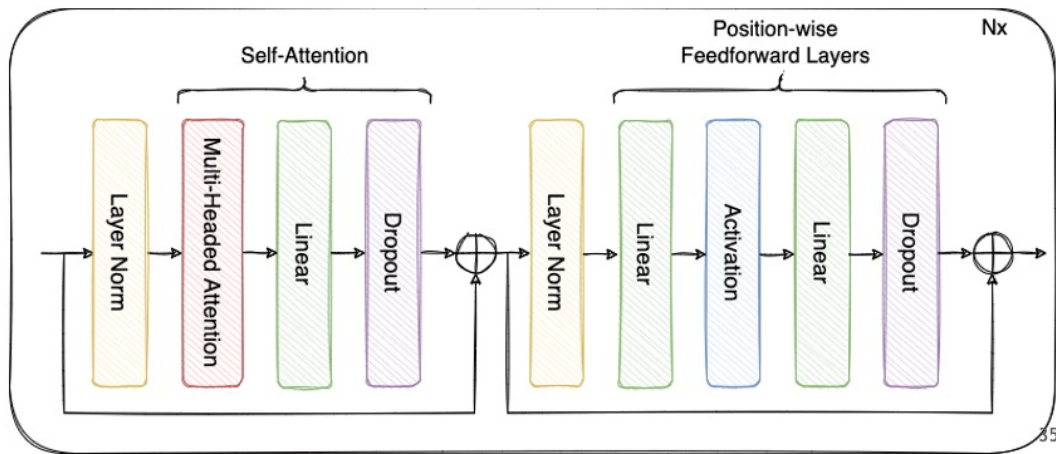

35

Tensor Parallelism (Intra-Layer)

MLP

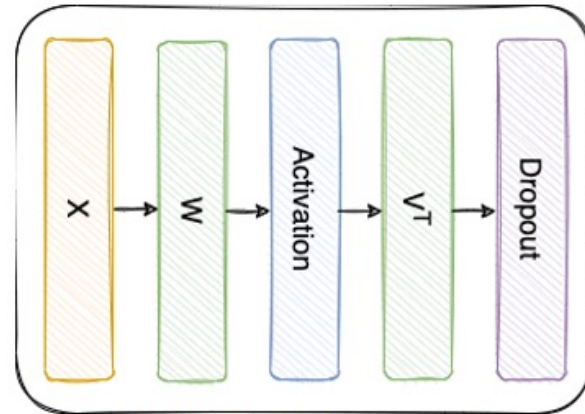

Split weights W and V^T across multiple GPUs

$$W = [W_1, W_2, W_3, W_4] \quad V = \begin{bmatrix} V_1 \\ V_2 \\ V_3 \\ V_4 \end{bmatrix}$$

Tensor Parallel = 4 MLP

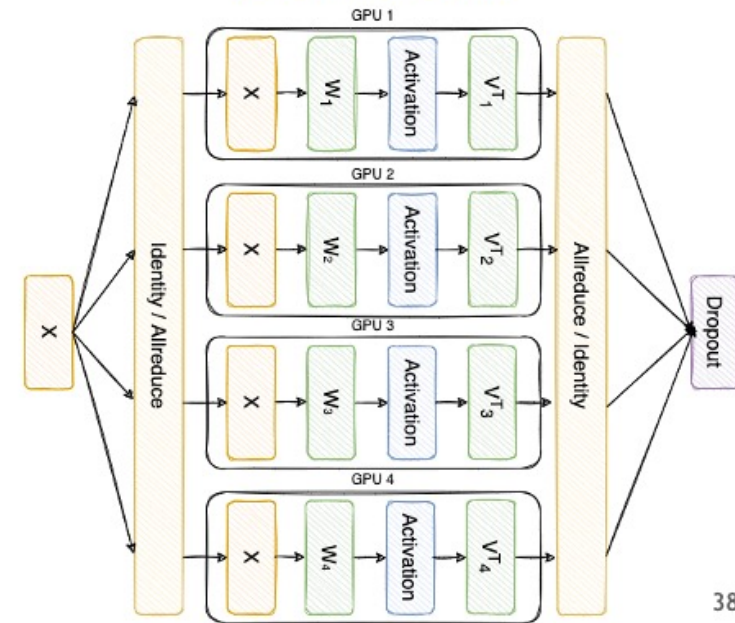

38

Easily understandable, but how?

Tensor Parallelism

- Mathematical principle of tensor parallelism (e.g. GEMM)
 - 1D: segmenting a matrix by **column** or row only
 - First linear layer $Y = XA$: $A = [A_1, A_2] \rightarrow Y = [XA_1, XA_2] = [Y_1, Y_2]$

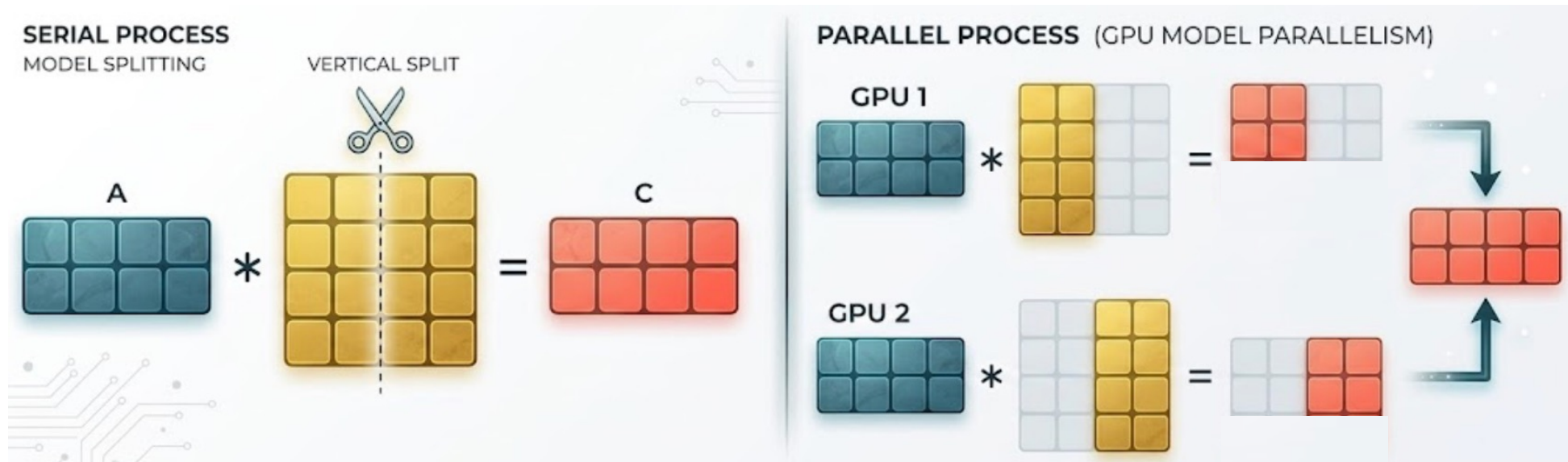

Tensor Parallelism

- Mathematical principle of tensor parallelism (e.g. GEMM)
 - 1D: segmenting a matrix by **column** or row only

- Second linear layer $Z = YB$:

$$Z = [Y_1 \ Y_2] \cdot \begin{bmatrix} B_1 \\ B_2 \end{bmatrix}$$

- Compute $Y_i B_i$ independently and aggregate $Z = Y_1 B_1 + Y_2 B_2$
 - Question: memory usage? communication load? end-to-end latency?
 - $1/P$ computation, $1/P$ parameter, Full activation, $2(P - 1)/P$ communication load, $2(P-1)$ latency

Tensor Parallelism

- Mathematical principle of tensor parallelism (e.g. GEMM)

- 1D: segmenting a matrix by column or **row** only

- *First linear layer* $Y = XA: \rightarrow Y = [X_1 \ X_2] \begin{bmatrix} A_1 \\ A_2 \end{bmatrix}$

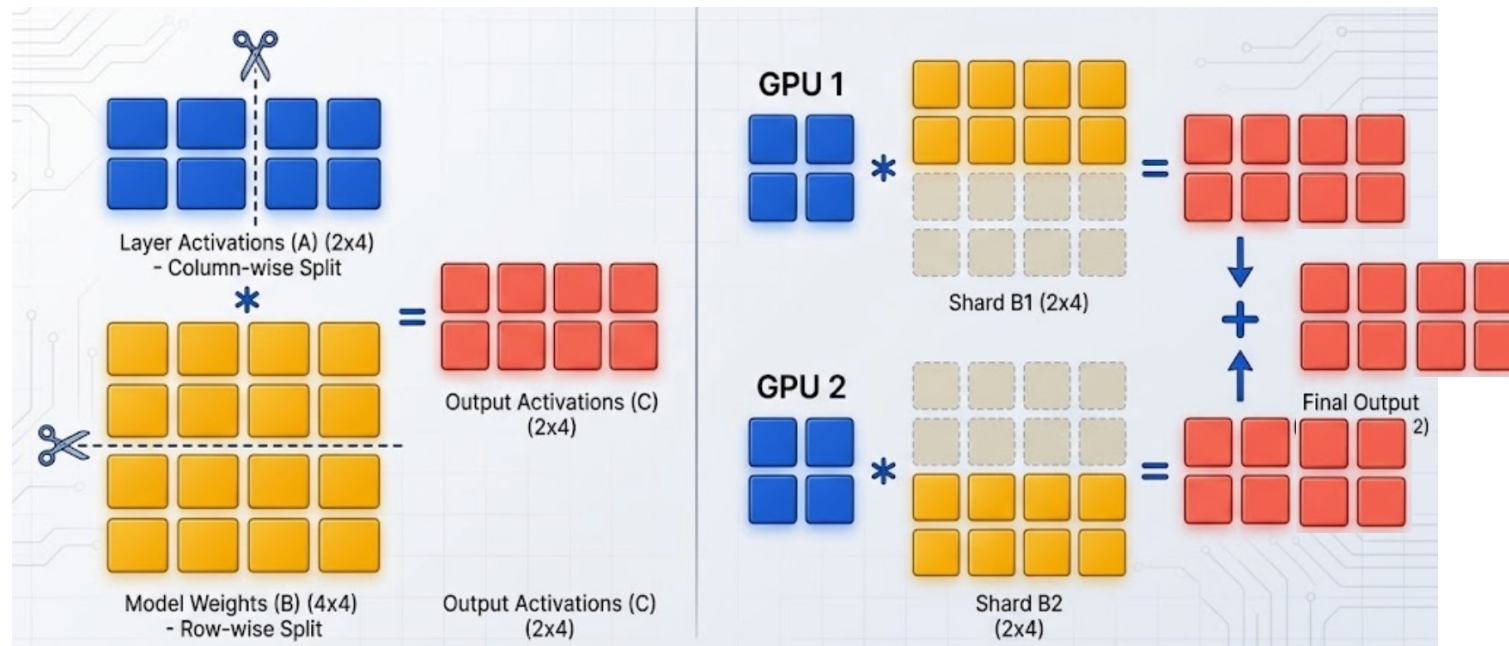

Tensor Parallelism

- Mathematical principle of tensor parallelism (e.g. GEMM)
 - 1D: segmenting a matrix by column or **row** only

- *Second linear layer $Z = YB$:*

$$Z = \begin{bmatrix} Y_1 \\ Y_2 \end{bmatrix} \cdot [B_1 \ B_2]$$

- *Compute $Y_i B_i$ independently and aggregate $Z = Y_1 B_1 + Y_2 B_2$*
- Question: memory usage? communication load? end-to-end latency?
 - 1/P computation, 1/P parameter, Full activation, 2(P-1)/P communication load, 2(P-1) latency

Tensor Parallelism

- How to split matrices
 - The column-wise and row-wise styles can be combined for multiple linear layers

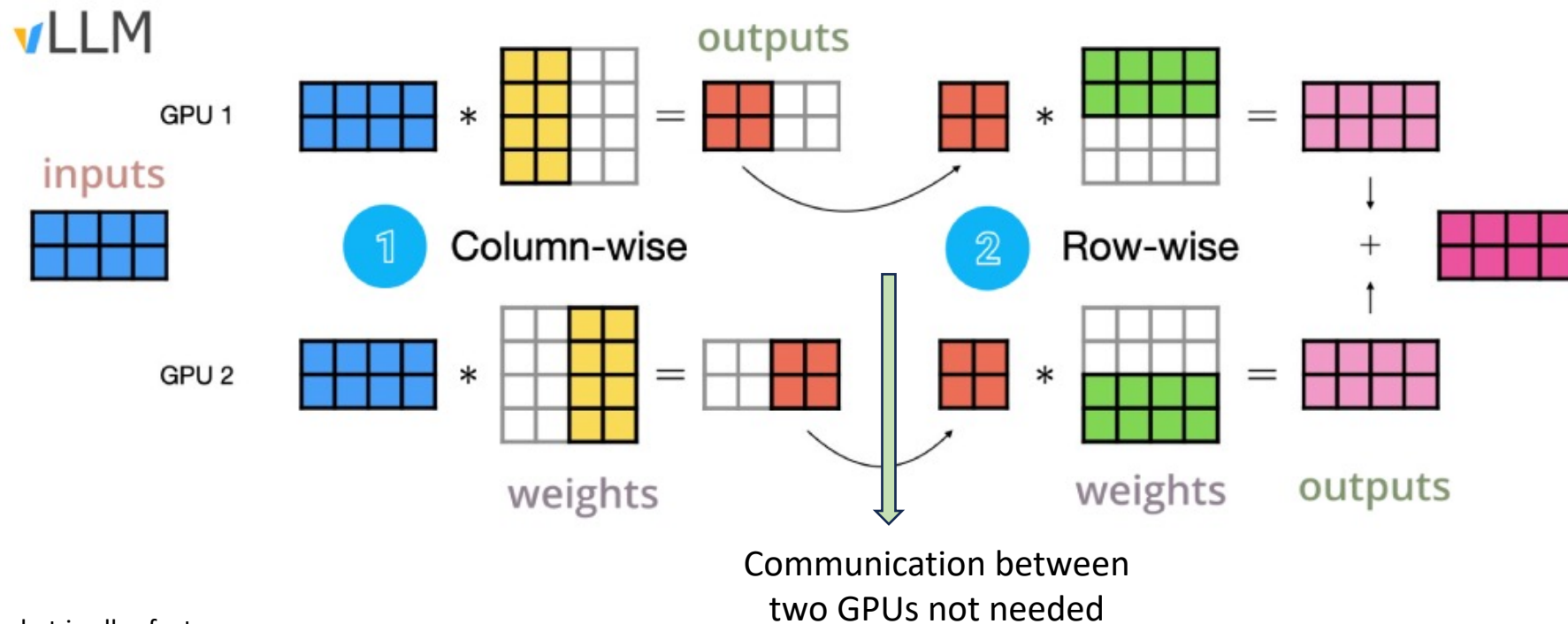

Tensor Parallelism

- Transformer MLP

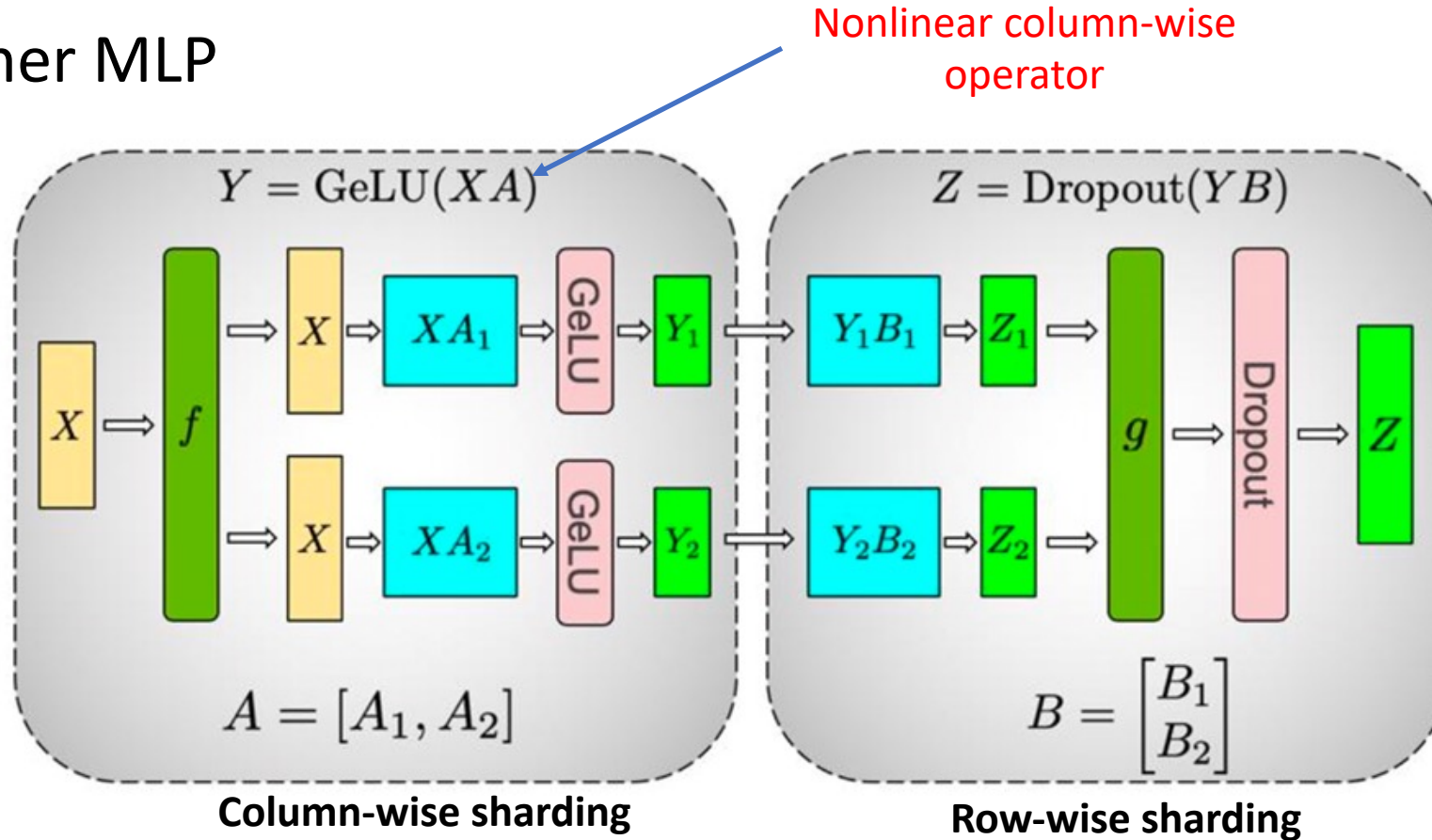

f and g are **conjugate**, f is identity operator in the forward pass and all-reduce in the backward pass while g is all-reduce in forward and identity in backward

Tensor Parallelism

- Transformer MLP

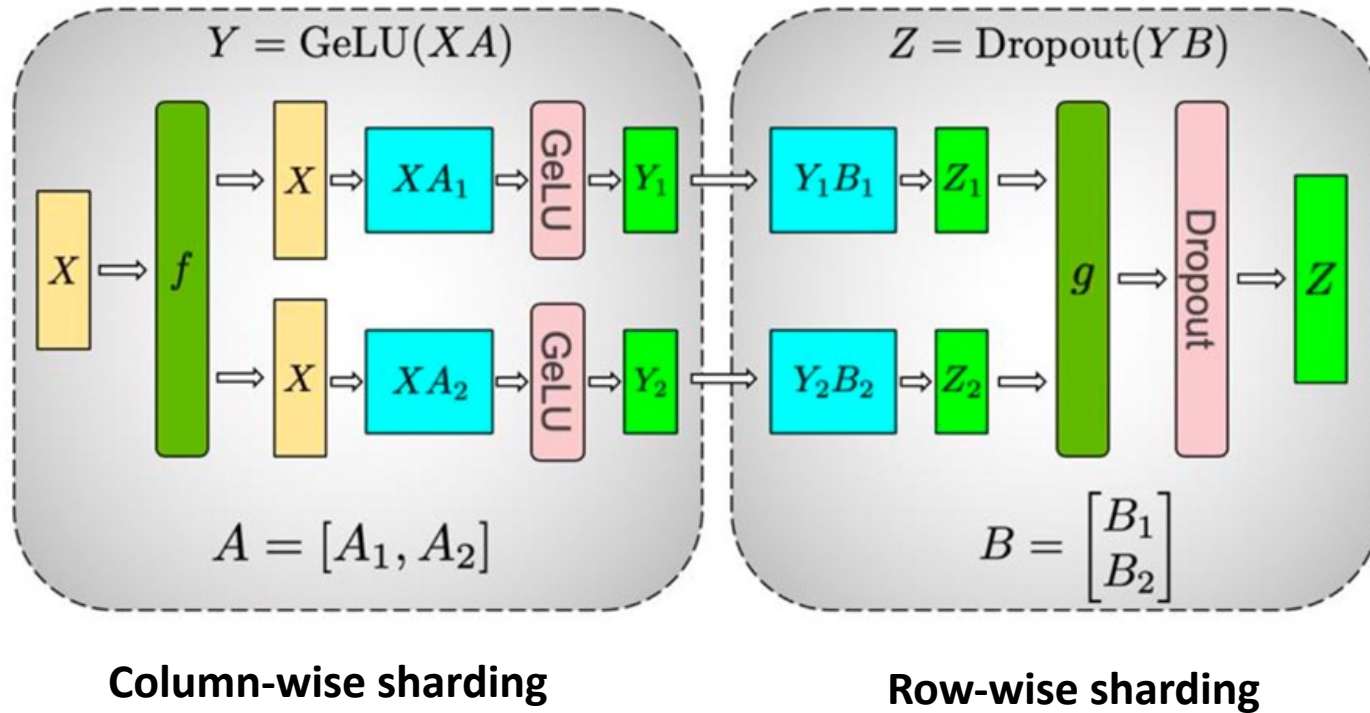

- Partition A by **columns** and B by **rows**
- Forward pass
 - “Copy” X to both GPUs via f
 - Execute math operations
 - “Add” Z_1 and Z_2 for a complete output Z via g
- Backward pass
 - “copy” $\partial L / \partial Z$ to both GPUs via g
 - Execute math operations
 - “Add” partial derivatives of X on two paths via f

Tensor Parallelism

- Transformer MLP: *communication analysis*

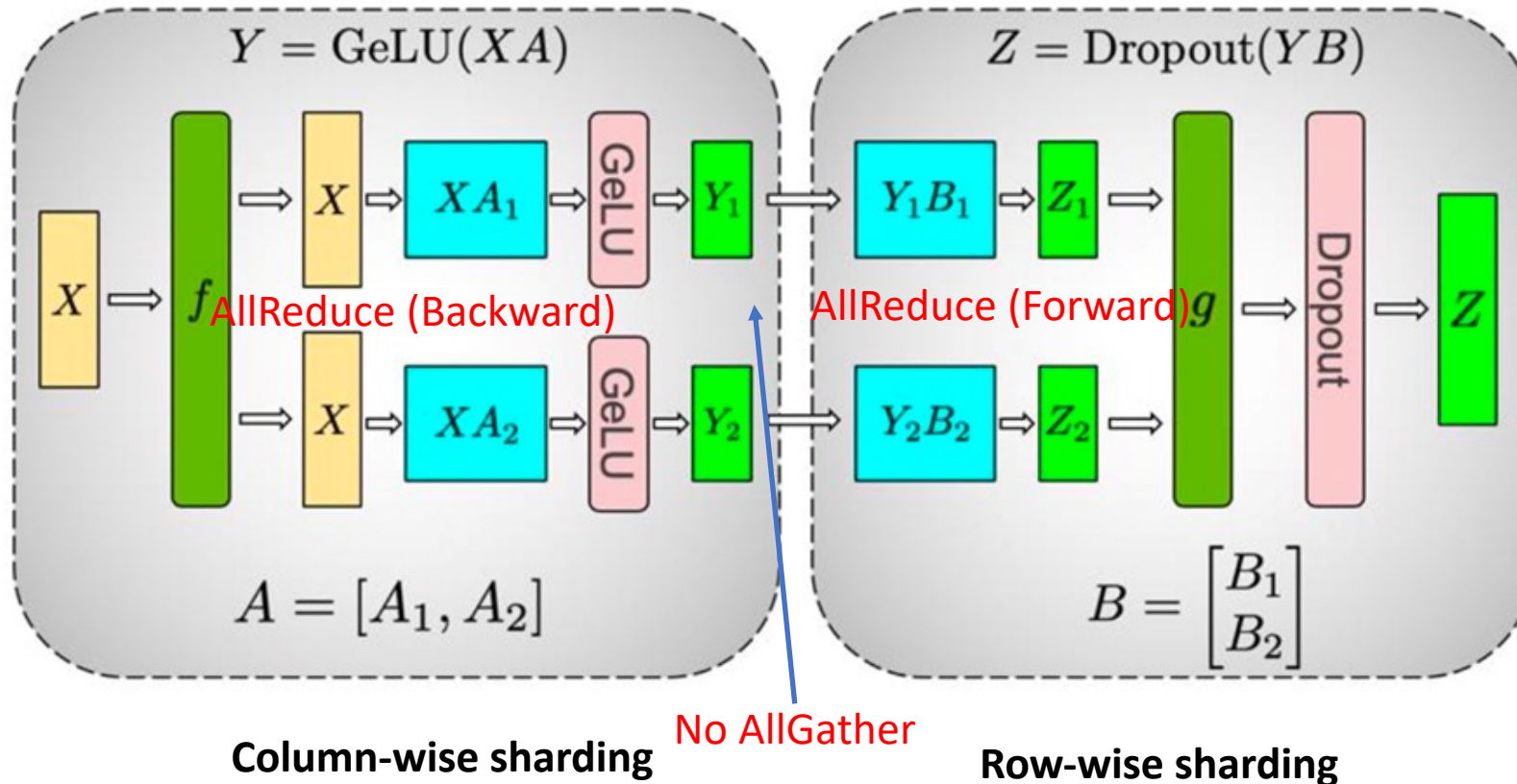

f and g are **conjugate**, f is identity operator in the forward pass and all-reduce in the backward pass while g is all-reduce in forward and identity in backward

Tensor Parallelism

- Transformer Self-Attention

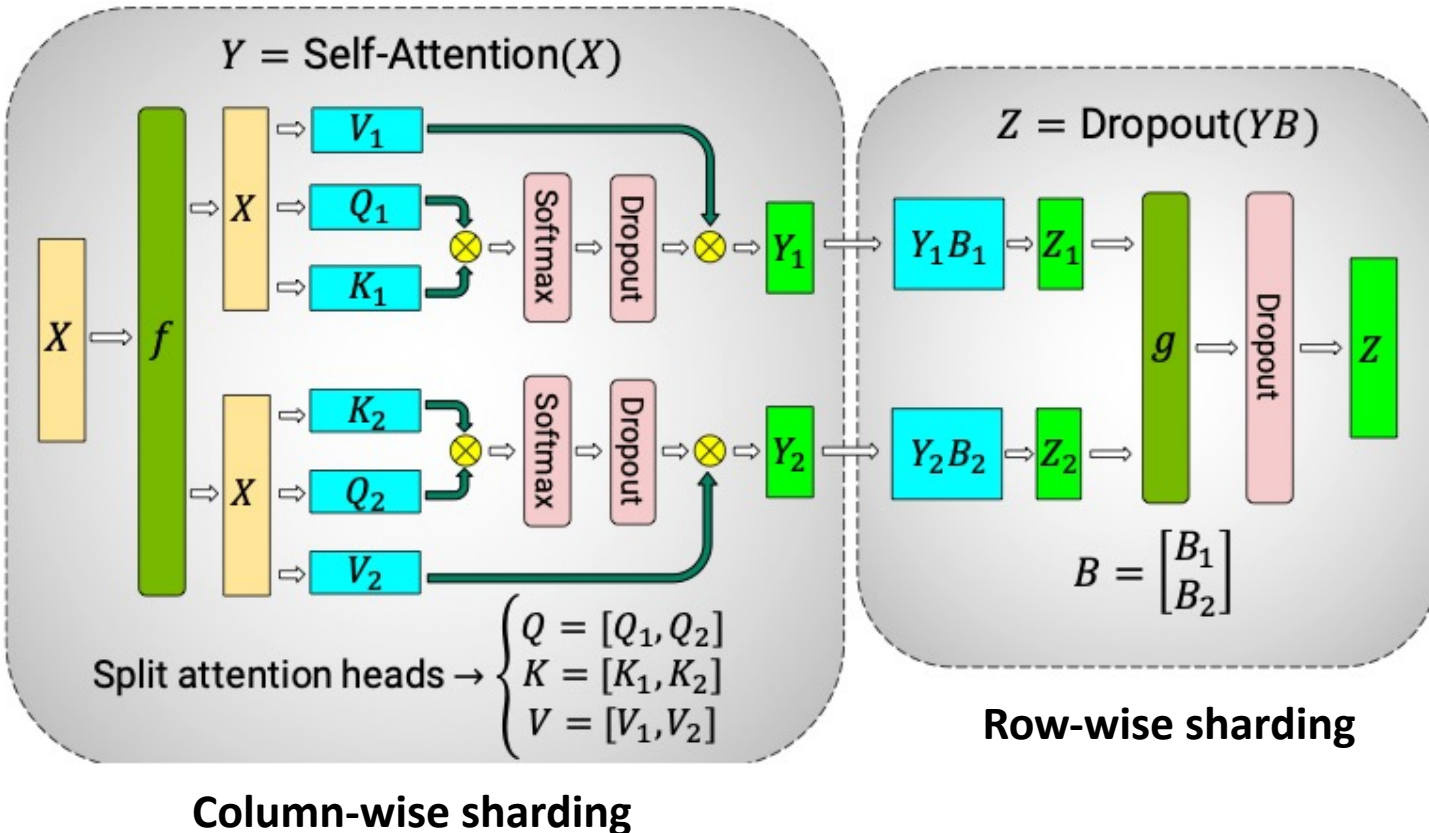

- Partition three parameter matrices W_Q , W_K and W_V by columns and partition the linear layer B by rows
- Forward pass
 - “Copy” X to both GPUs via f
 - Execute math operations such as computing Q, K, V
 - “Add” Z_1 and Z_2 for a complete output Z via g
- Backward pass
 - “copy” $\partial L / \partial Z$ to both GPUs via g
 - Execute math operations
 - “Add” partial derivatives of X on two paths via f

Tensor Parallelism

- Transformer Self-Attention

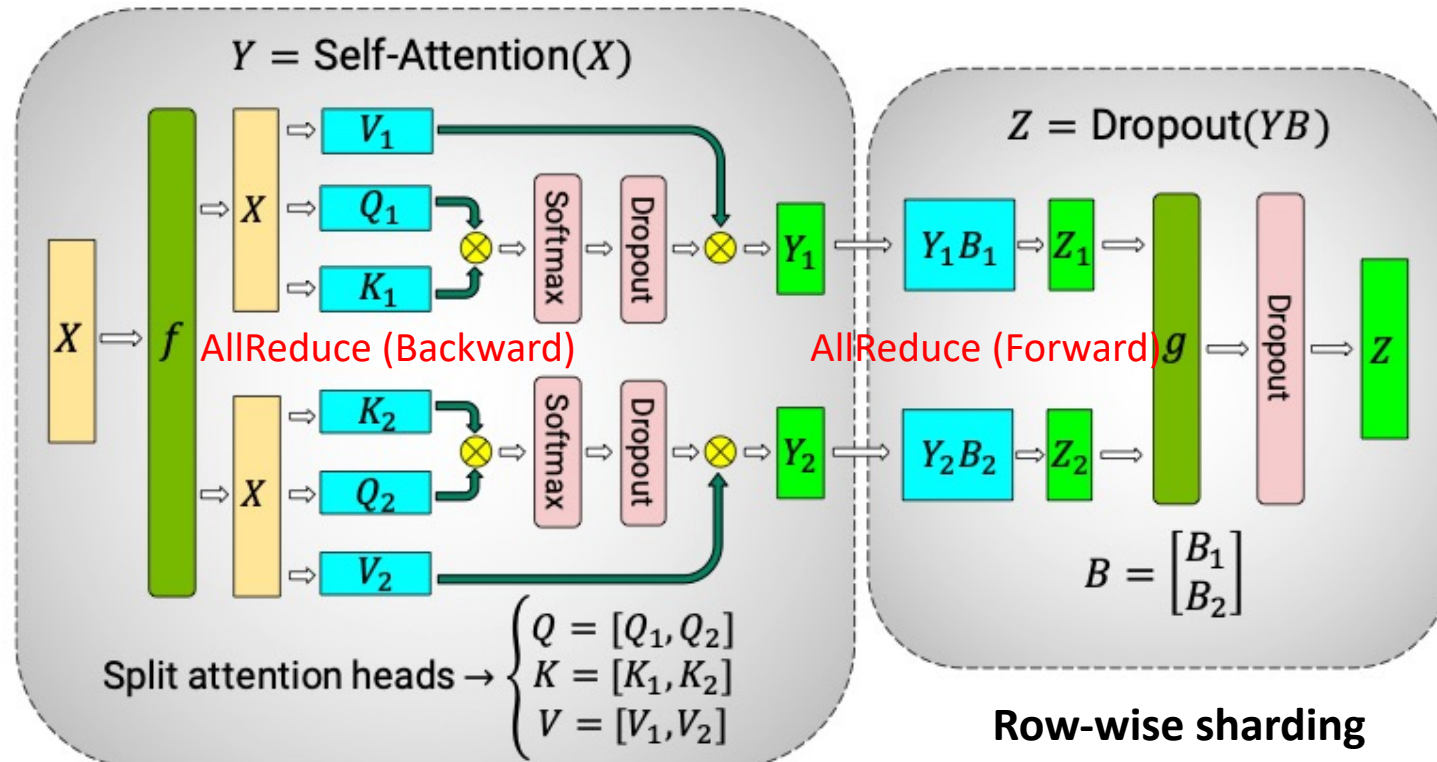

Column-wise sharding

Row-wise sharding

f and g are **conjugate**, f is identity operator in the forward pass and all-reduce in the backward pass while g is all-reduce in forward and identity operator in backward

Tensor Parallelism

- TP communication analysis

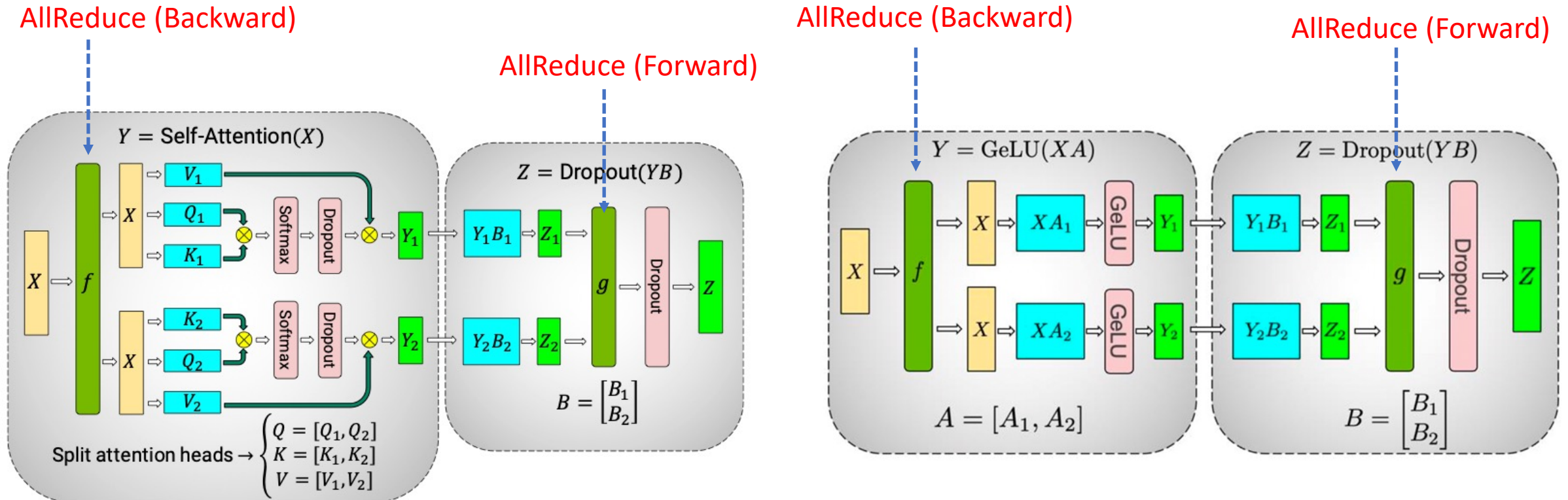

Tensor Parallelism

- Transformer layer: communication analysis

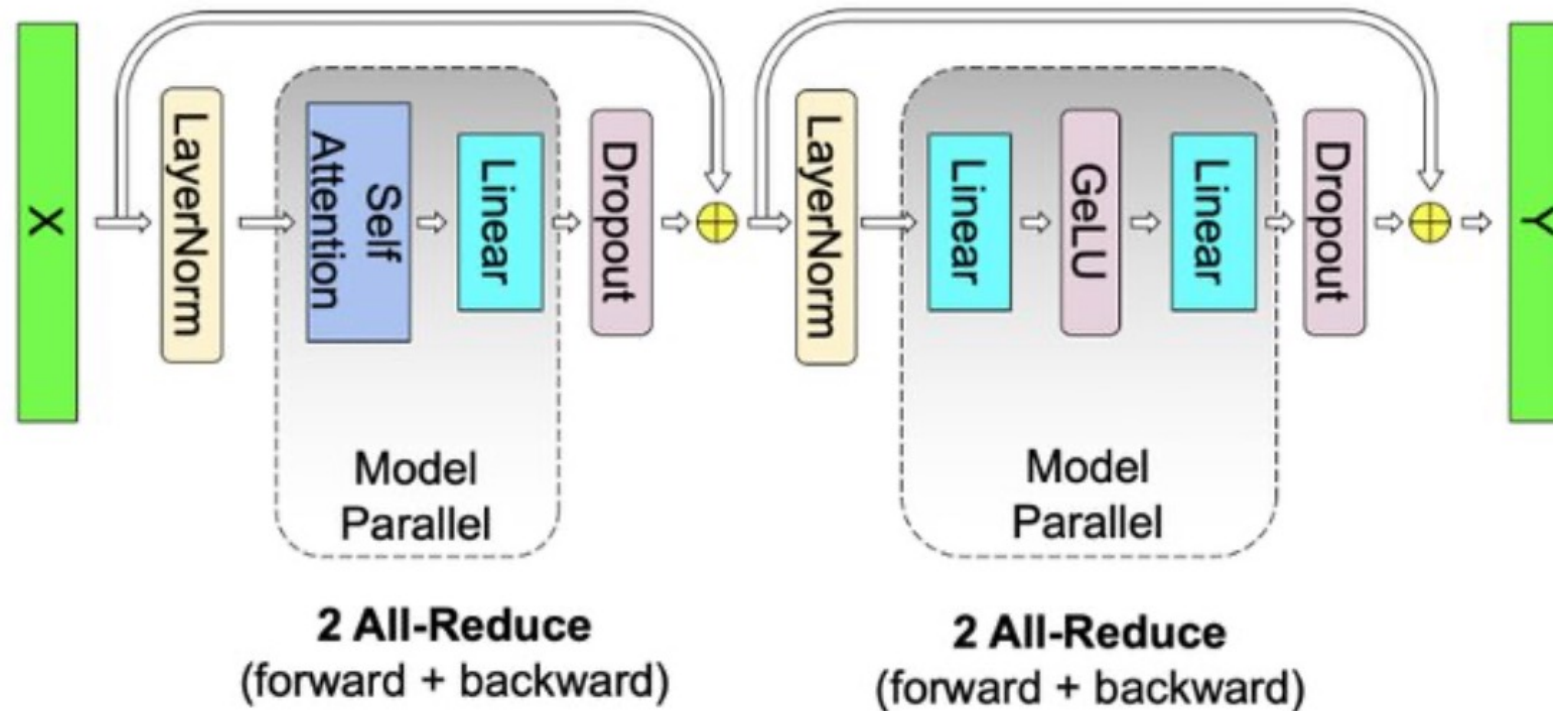

Total communication complexity: 8Φ . (Φ is the volume of the corresponding parameters)

《Accelerating Large Language Model Training with Hybrid GPU-based Compression》

Tensor Parallelism

- Submatrix Multiplication
 - More GPUs working simultaneously

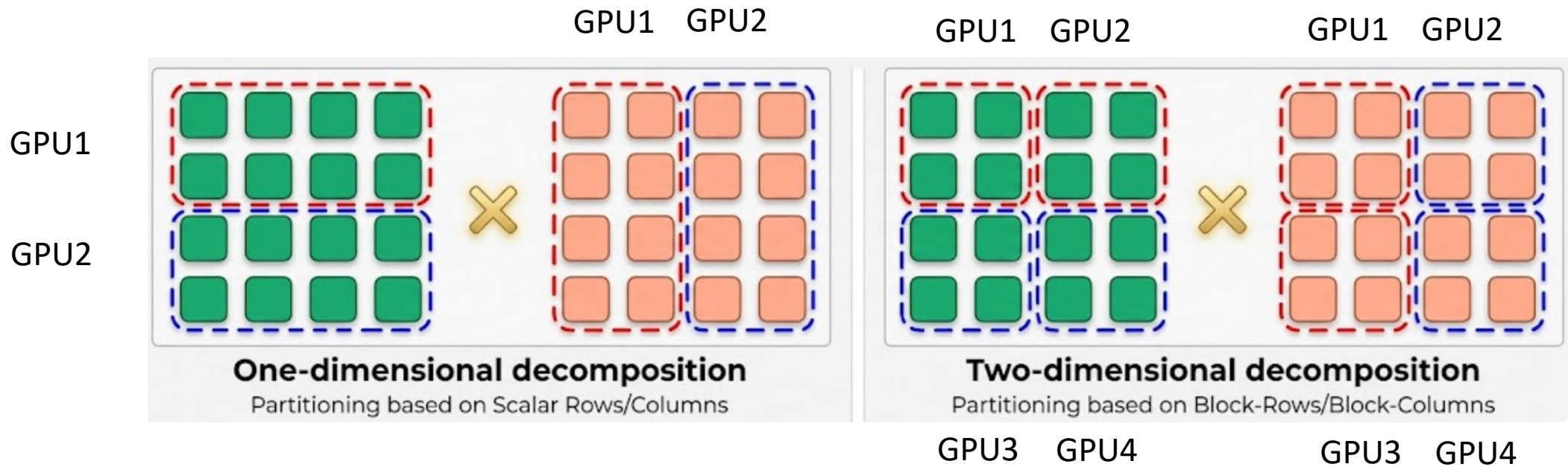

(Extended Learning)

Tensor Parallelism

- 2D Tensor Parallelism: each color represents a different GPU

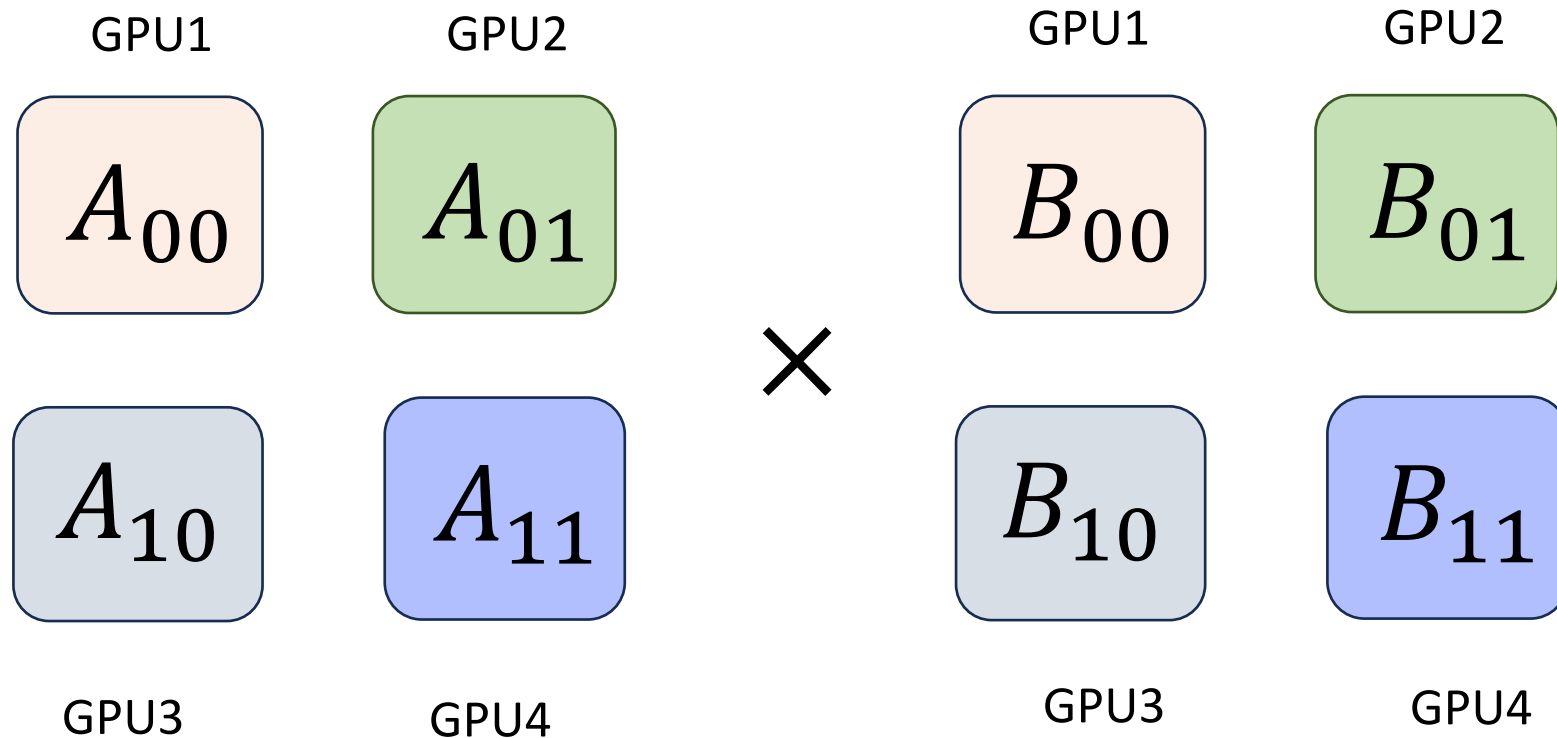

(Extended Learning)

Tensor Parallelism

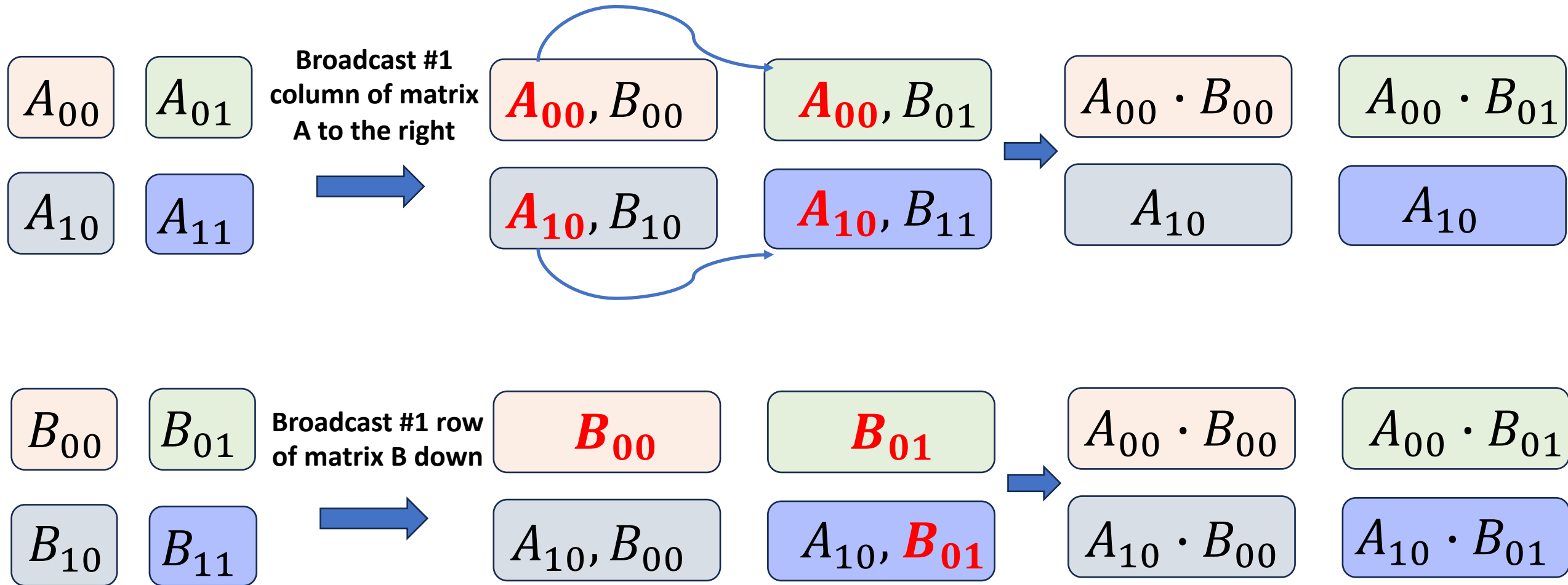

(Extended Learning)

Tensor Parallelism

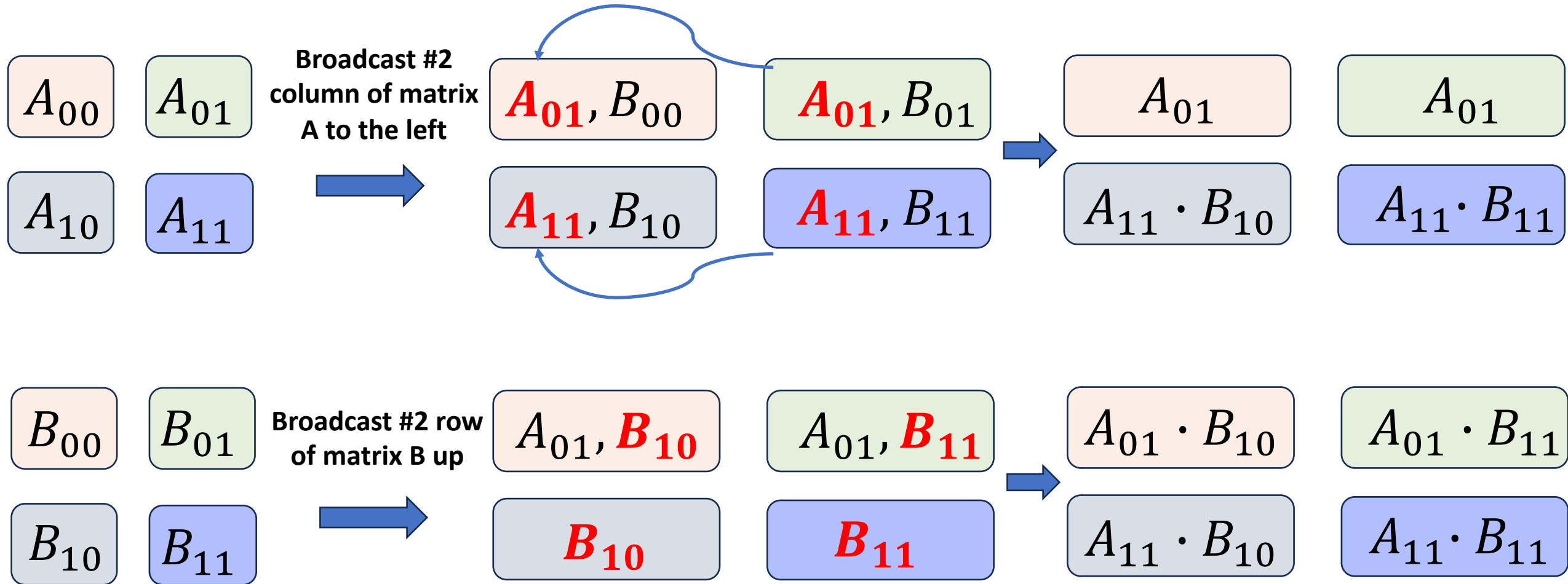

Tensor Parallelism

- 2D Tensor Parallelism

Sequential computation

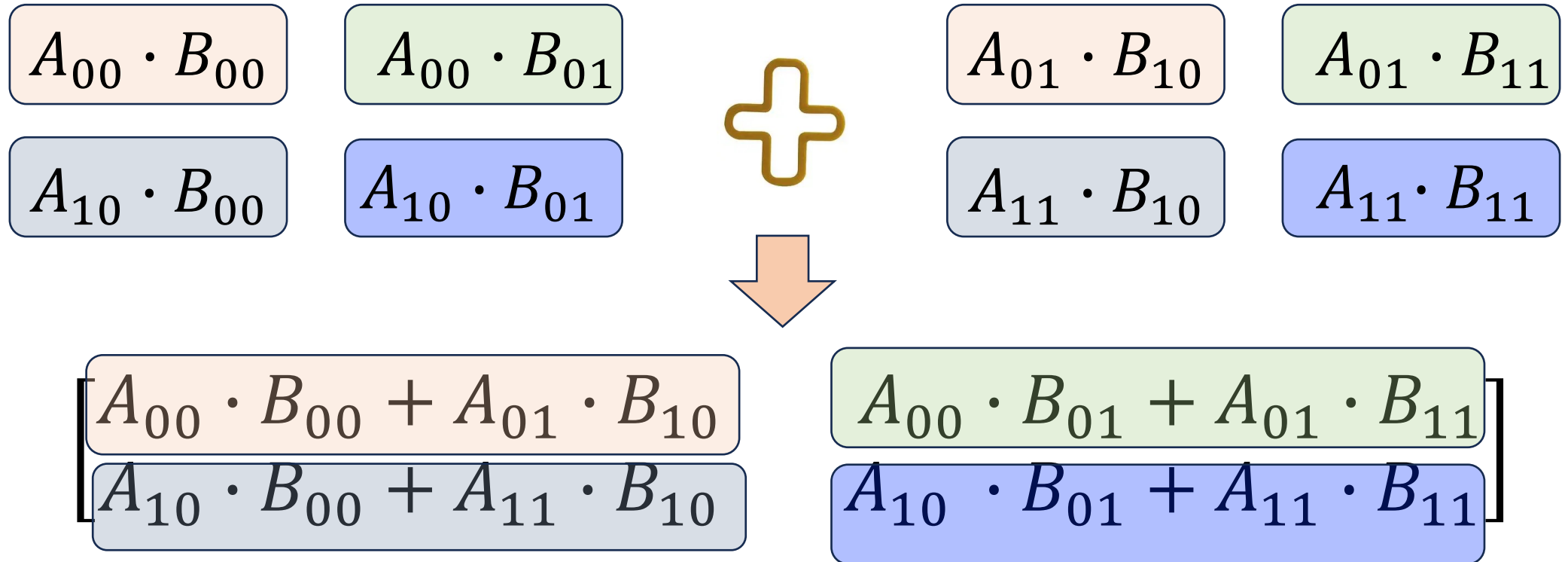

- 2D Tensor Parallelism with more rows and columns?

Tensor Parallelism

- 2D Tensor Parallelism: general procedure on $Y = AB$
 - Demand $P = q^2$ GPUs, and partition both input and parameters on P GPUs

Less per-GPU communication

computation, memory and communication complexity

- Computation: $O\left(\frac{1}{P}\right)$
- Memory (parameter and activation): $O\left(\frac{1}{P}\right)$
- Communication: $O\left(\frac{1}{q}\right)$ (note that broadcast is replaced by All-Gather)

Tensor Parallelism

- Recap
 - Tensor parallelism segments matrix on **feature dimensions** (i.e. hidden dimension and out dimension) that addresses the multiplication of large weight matrices
 - Tensor parallelism introduces **multiple AllReduce operations** that demand nontrivial communication burdens, and is thus constrained by the high bandwidth domain
 - Only for Attention and MLP
 - Keeping the entire input and output to the Attention and MLP layers

Distributed LLM Training: Outline

- Data Parallelism
 - Parameter-Server
 - All-Reduce
 - Memory Optimization

- Model Parallelism
 - Pipeline Parallelism
 - Tensor Parallelism

- **Sequence Parallelism**

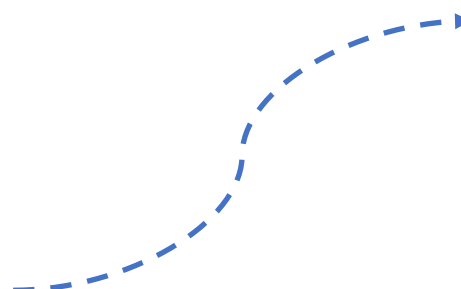

Sequence parallelism and context parallelism are mixed in this subsection

- Mixture of Experts

Sequence Parallelism

- Sequence Parallelism
 - Tensor parallelism reduces the memory footprint of **model data**, how about **non-model data**?
 - Activation memory is $O(n^2)$ in *self-attention* with n being the sequence length
 - Attention scores not stored in HBM
 - Activations include **Q , K , V** matrices

$$\text{Attention}(Q, K, V) = \text{softmax}\left(\frac{QK^T}{\sqrt{d_k}}\right)V$$

- *Some layers have not been parallelized: layernorm and dropout*

Sequence Parallelism

- Sequence Parallelism

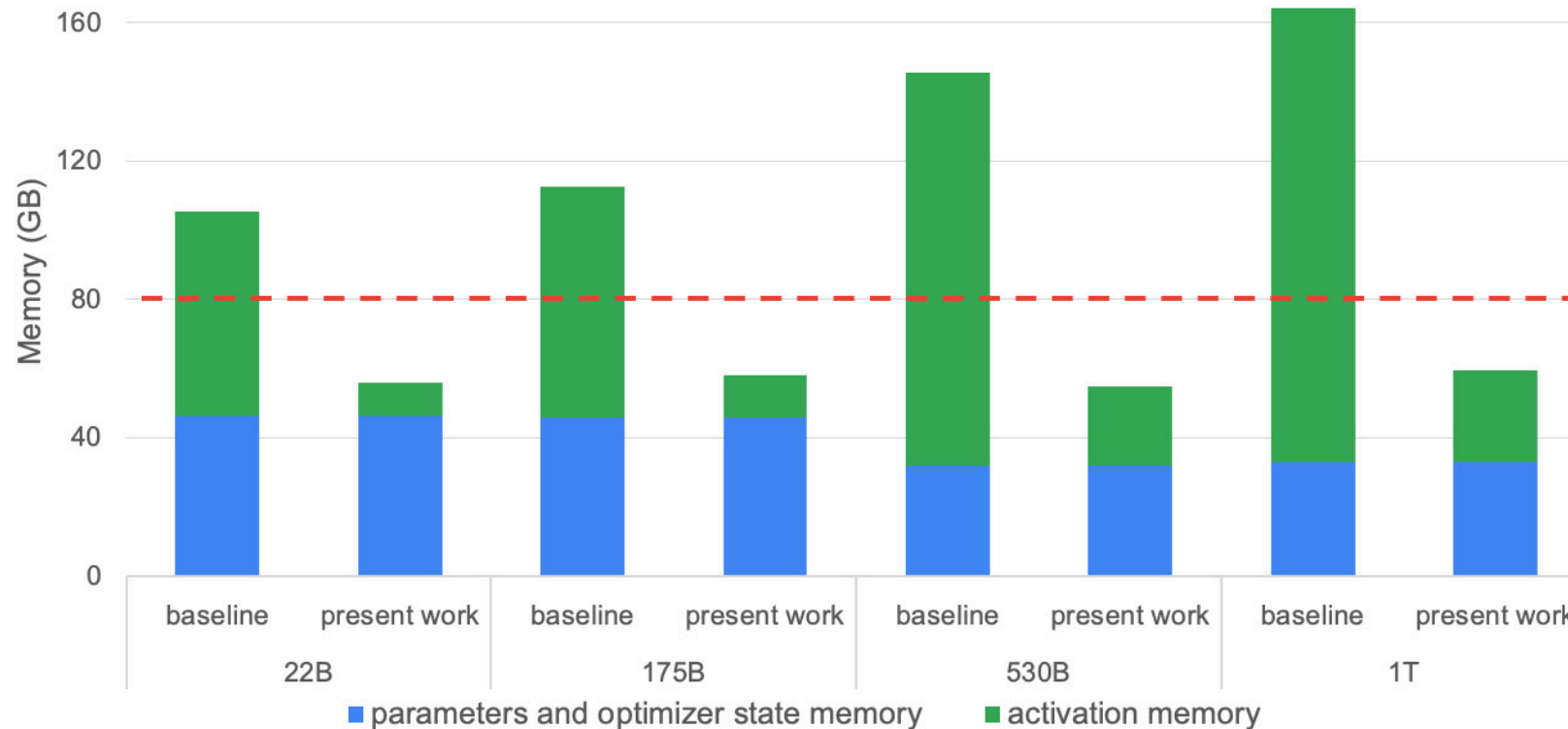

Parameters, optimizer state, and activations memory

《Reducing Activation Recomputation in Large Transformer Models》

Sequence Parallelism (Recap)

- Activation is non-negligible

- Forward propagation
- Backward propagation
- Size of activation

- Standard transformer: b - batch size, s - sequence length, h - hidden layer dimension

Output of a previous layer, intermediate variable

$$y = Wx + b$$

$$\frac{dL}{dW} = \frac{dL}{dy} x$$

Cannot be discarded after FP

bsh * 2 Bytes

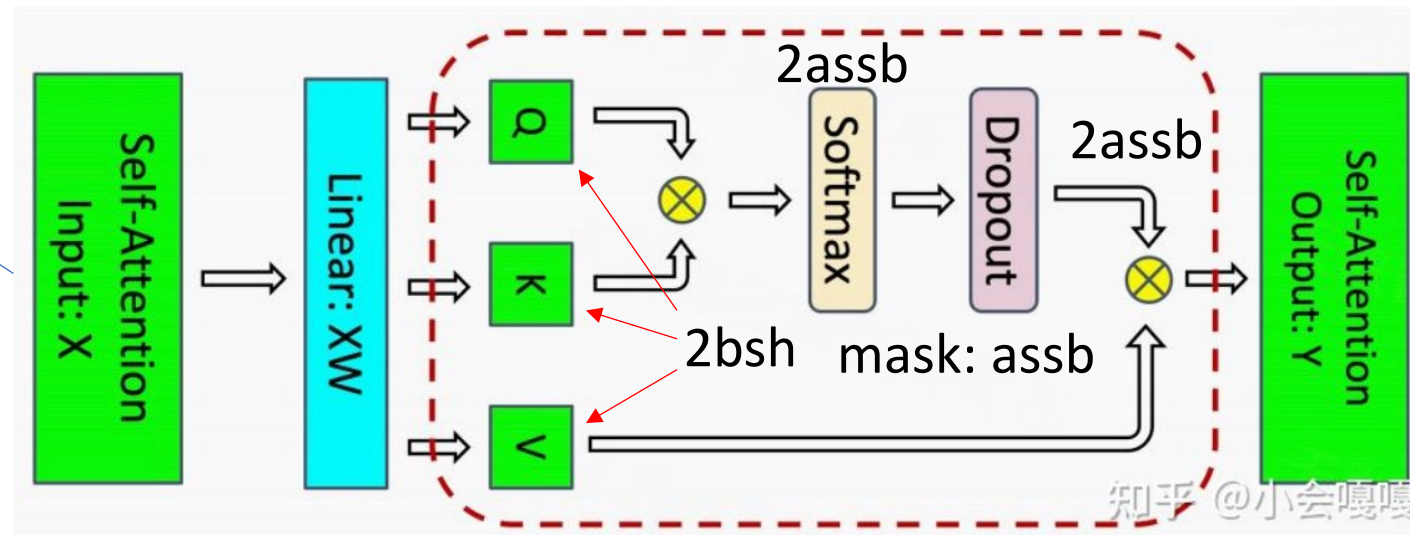

In-total: 5abss + 8sbh

Sequence Parallelism (Recap)

- Activation is non-negligible

- Forward propagation
- Backward propagation
- Size of activation

- Standard transformer: b - batch size, s - sequence length, h - hidden layer dimension

Output of a previous layer, intermediate variable

$$y = Wx + b$$

$$\frac{dL}{dW} = \frac{dL}{dy} x$$

Cannot be discarded after FP

bsh * 2 Bytes

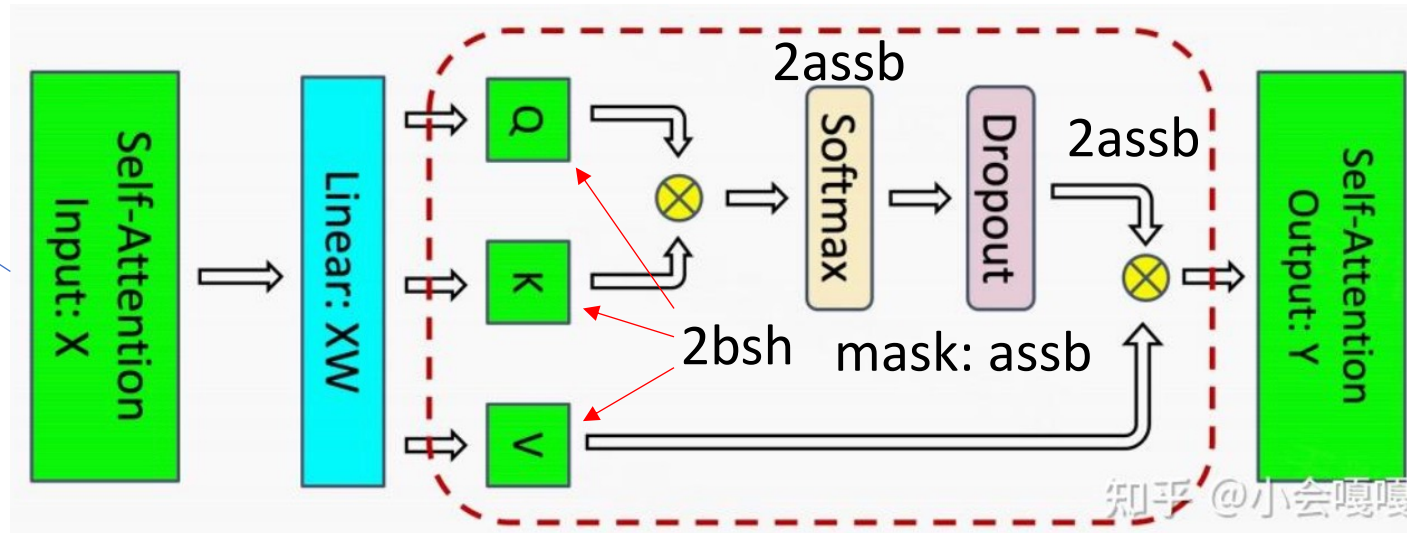

3sbh: Linear layer + dropout layer

In-total: 5abss + 11sbh

Sequence Parallelism (Recap)

- Activation is non-negligible

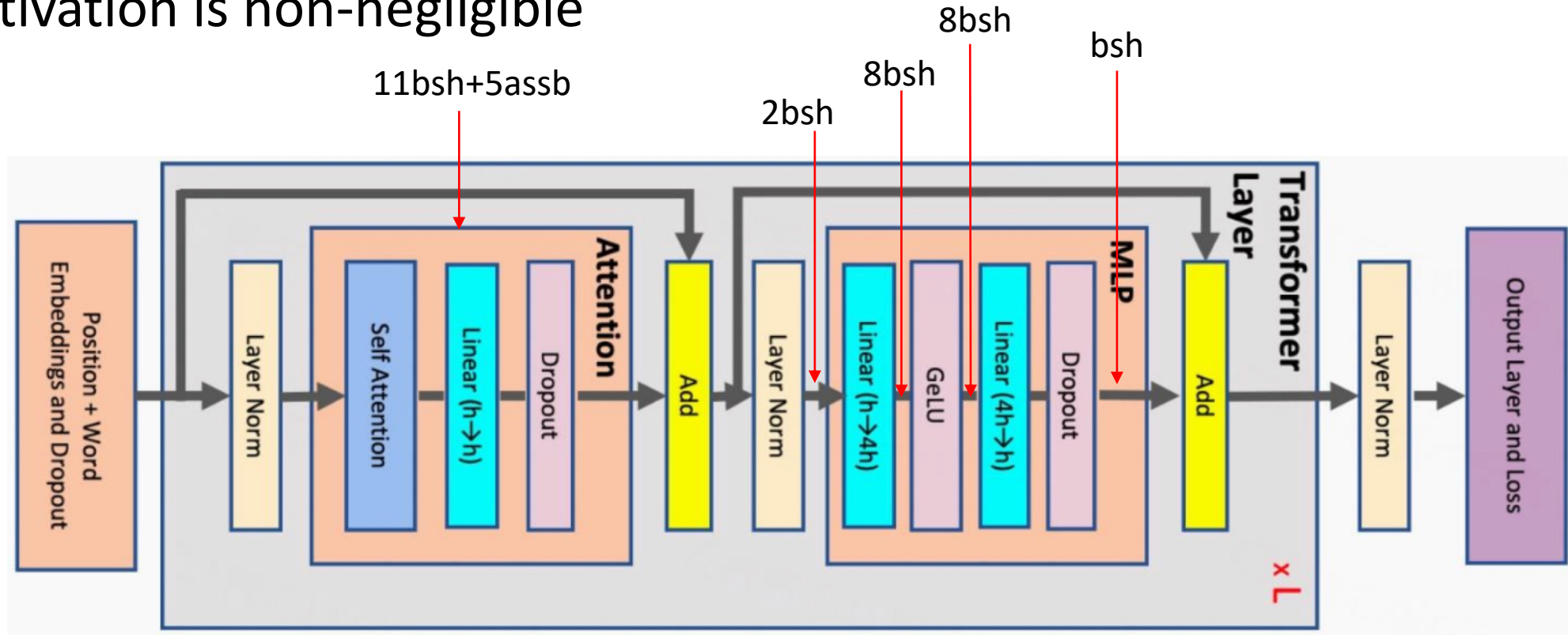

In-total: $5abss + 34sbh$

Sequence Parallelism

- Representative SP frameworks
 - Megatron-LM SP
 - 《Reducing Activation Recomputation in Large Transformer Models》
 - Deemed as a further optimization of Tensor Parallelism
 - DeepSpeed Ulysses (**Extended Learning**)
 - 《DeepSpeed Ulysses: System Optimizations for Enabling Training of Extreme Long Sequence Transformer Models》
 - Colossal AI SP (**Extended Learning**)
 - 《Colossal-AI: A Unified Deep Learning System For Large-Scale Parallel Training》
 - Megatron Context Parallelism (**Extended Learning**)
 - https://docs.nvidia.com/megatron-core/developer-guide/latest/api-guide/context_parallel.html

Sequence Parallelism

- Megatron-LM sequence parallelism

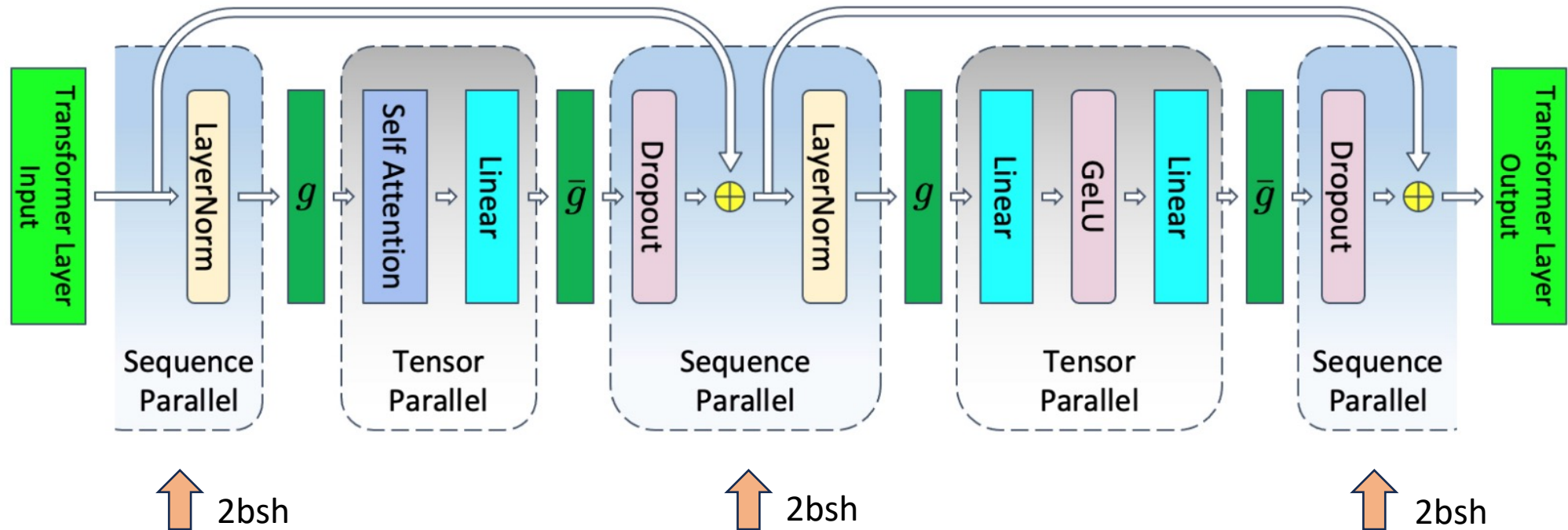

Tensor parallelism only segments inputs and outputs of *self-attention* and *MLP*

Sequence Parallelism

- Megatron-LM sequence parallelism
 - *layernorm* operation
 - The shape of an input matrix: [batch_size, seq_len, hidden_dim]
 - Compute mean, variance and a learnable affine transformation for each **TOKEN**
 - Can be naturally partitioned by tokens without any cross-device communication
 - *Dropout* operation
 - Each GPU compute dropout independently

Activations (input/output of layernorm) on each GPU: $\frac{2bsh}{t}$

Activations (dropout) on each GPU: $\frac{bsh}{t}$

Sequence Parallelism

- Megatron-LM sequence parallelism
 - Segmenting input sequence

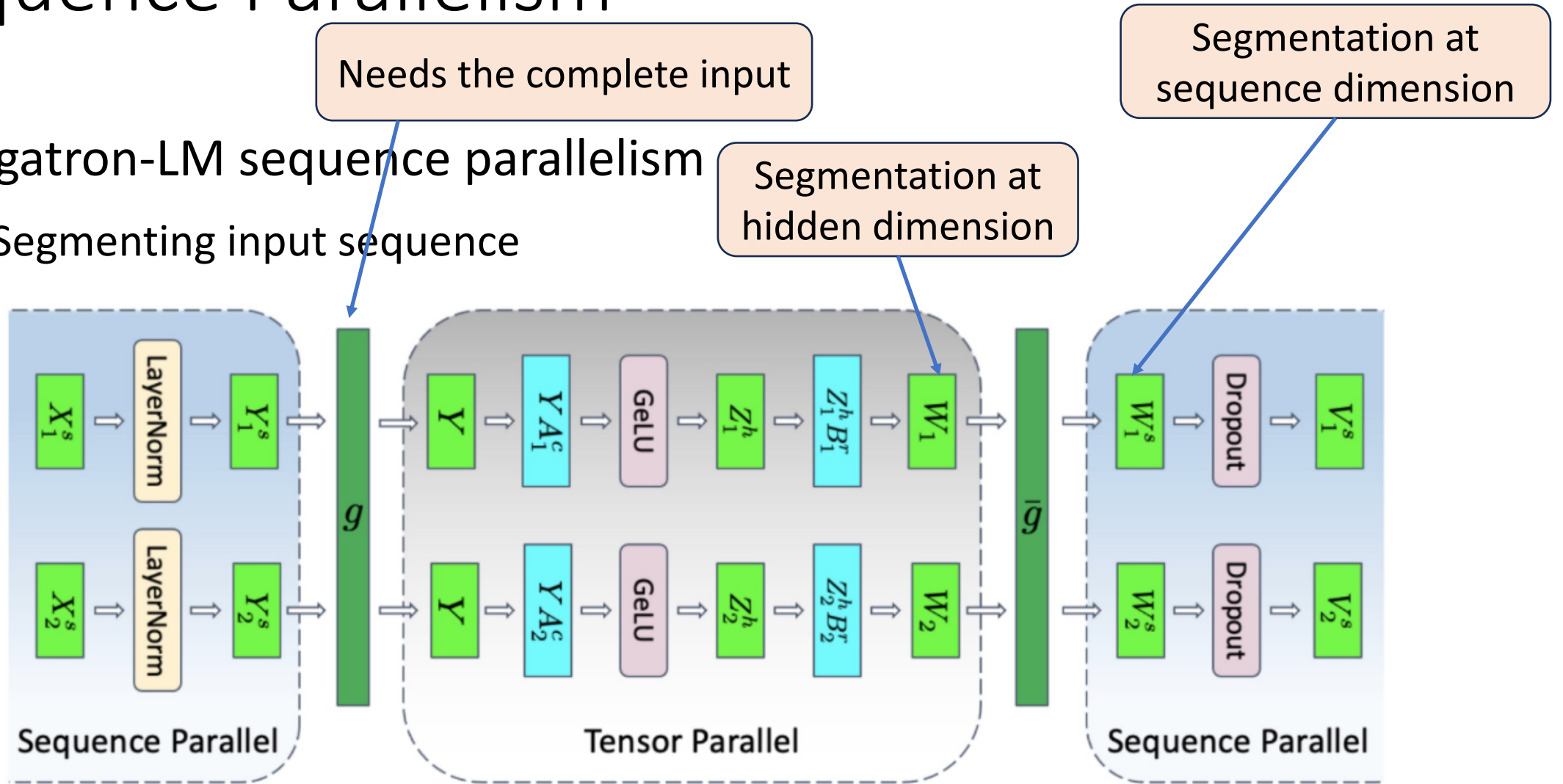

MLP layer with tensor and sequence parallelism. \mathbf{g} and $\bar{\mathbf{g}}$ are conjugate. \mathbf{g} is all-gather in forward pass and reduce-scatter in backward pass. $\bar{\mathbf{g}}$ is reduce-scatter in forward pass and all-gather in backward pass.

Sequence Parallelism

- Megatron-LM sequence parallelism
 - MLP layer (forward pass)

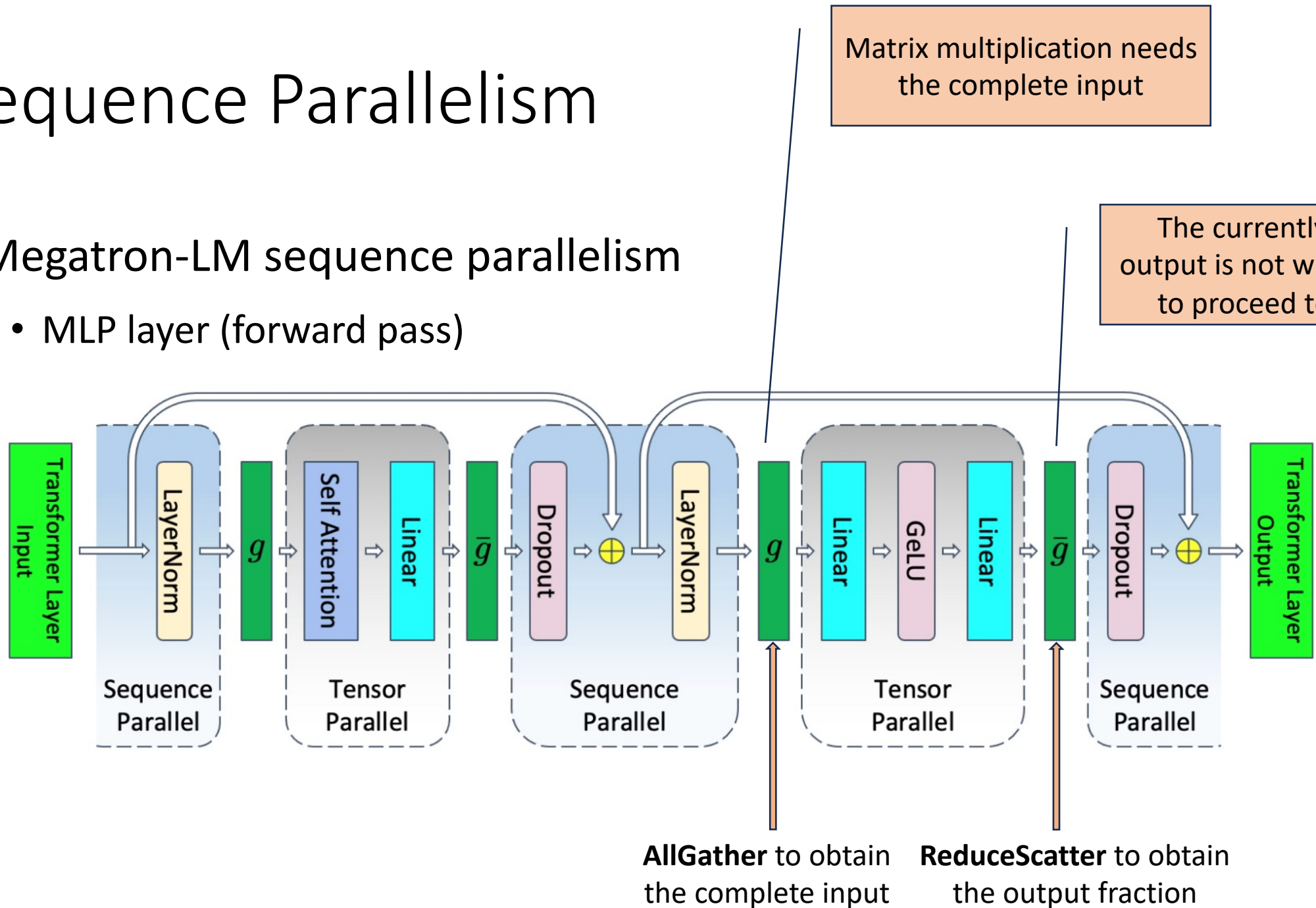

Sequence Parallelism

- Megatron-LM sequence parallelism
 - MLP layer (backward pass)

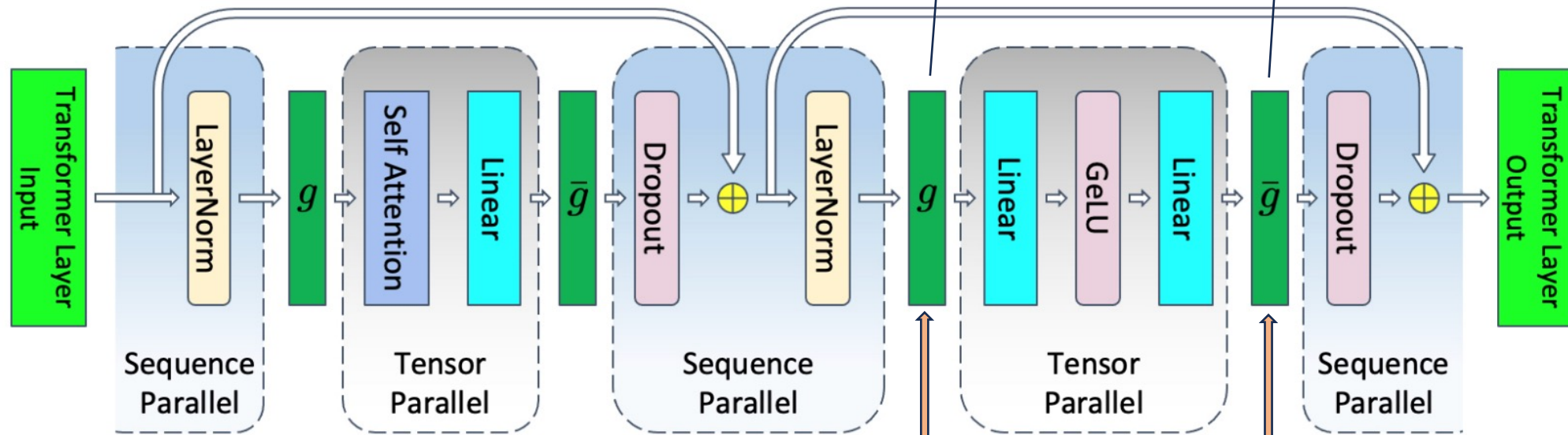

The currently buffered output is not what you need to proceed to Dropout

Matrix multiplication needs the complete input

Finally: $5bsh + \frac{16bsh}{t}$ becomes $\frac{21bsh}{t}$

ReduceScatter to obtain the output fraction

AllGather to obtain the complete input

Sequence Parallelism

- Megatron-LM sequence parallelism
 - Attention (forward pass, backward pass omitted)

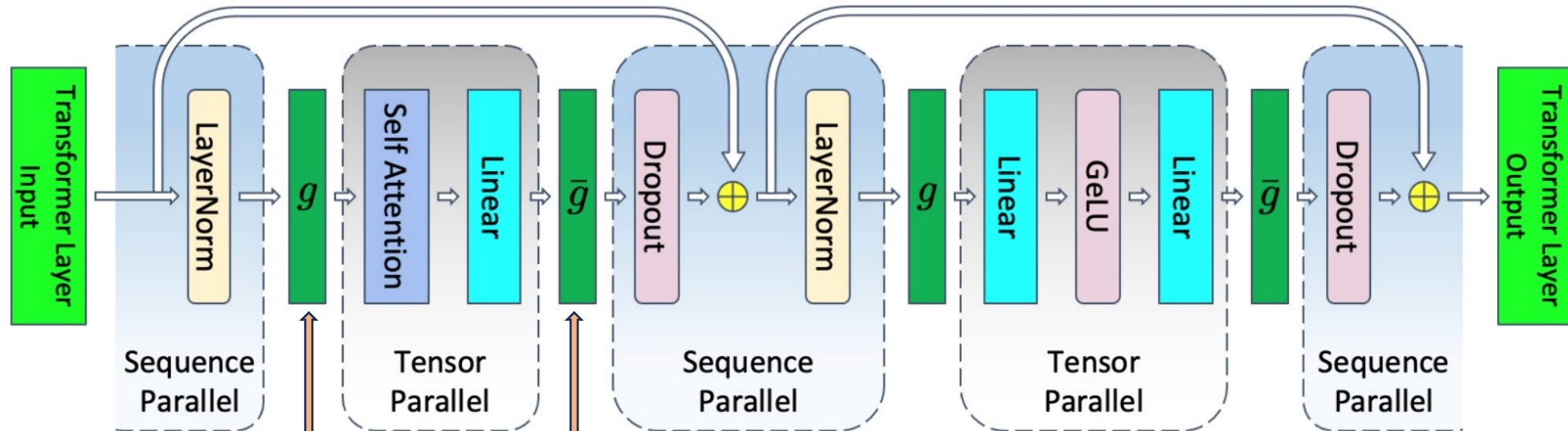

AllGather to obtain the complete input

ReduceScatter to obtain the output fraction

Finally: $5bsh + \frac{5bass+8bsh}{t}$ becomes $\frac{5bass+13bsh}{t}$

Sequence Parallelism

- Megatron-LM sequence parallelism
 - Slicing input/output of layernorm, and input of dropout
 - Changing AllReduce into ReduceScatter and AllGather
 - Almost **ZERO** extra communication overhead
 - Changing their memory consumption from $10bsh$ to $\frac{10bsh}{t}$
- An example: batch_size = 64, hidden_size = 4096, seq_len = 32768, sp = 8
 - Memory consumption per-block changes from 86 GB to 10.7 GB

Sequence Parallelism

- **ZERO** extra communication overhead

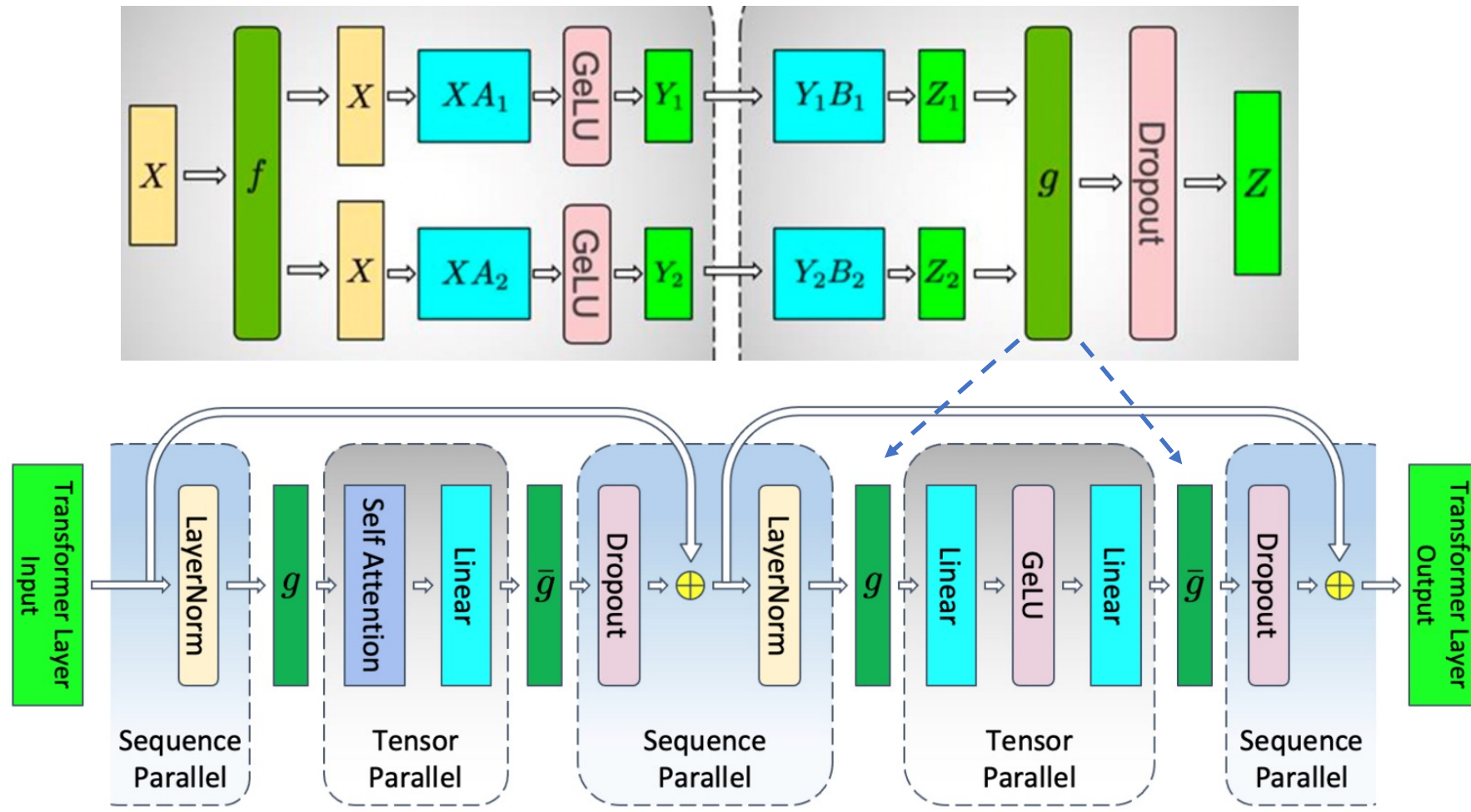

Sequence Parallelism

- DeepSpeed Sequence Parallelism
 - Megatron SP in fact slice activations at the token (sequence) dimension

How about slicing sequences in the very beginning?

(Extended Learning)

Sequence Parallelism

Mode not partitioned!

- DeepSpeed Ulysses Sequence Parallelism

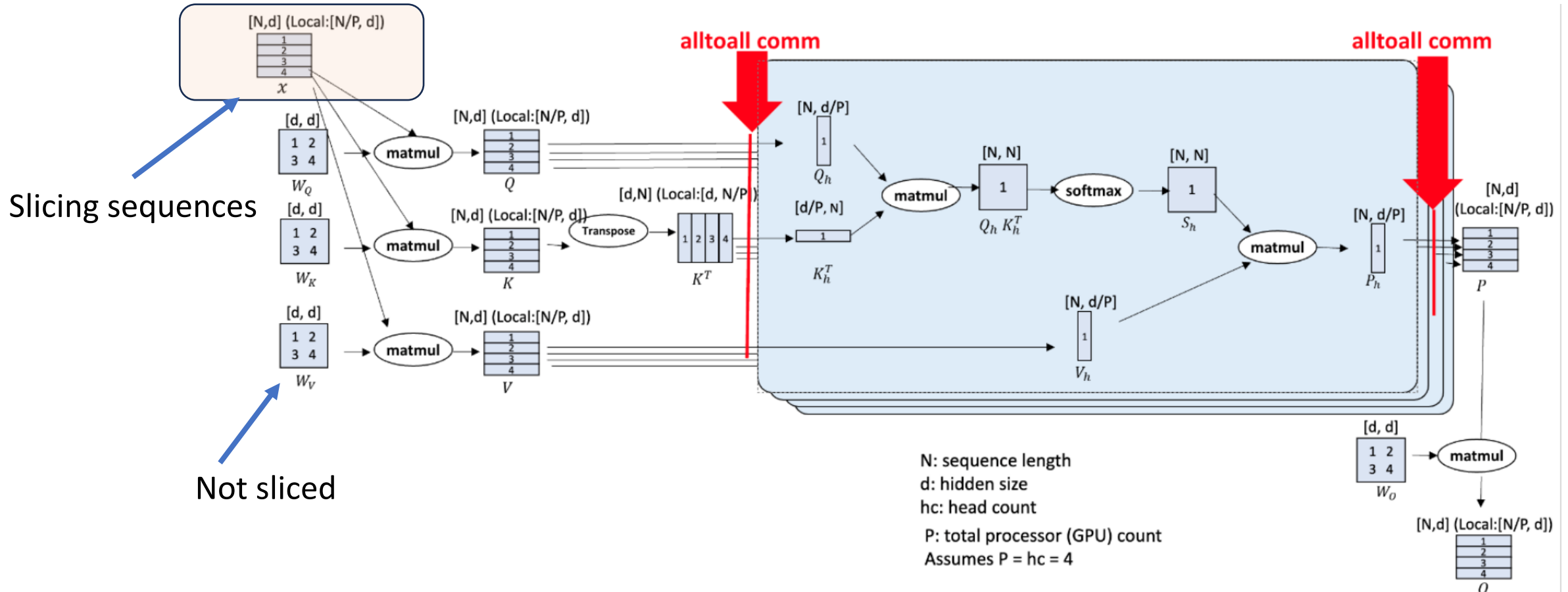

Slicing sequences

Not sliced

Sequence Parallelism

- DeepSpeed Ulysses Sequence Parallelism
 - Slicing input $X=(N, d)$, with N for sequence length and d for hidden dimension
 - Each GPU has an input $(N/P, d)$, with d for # of GPUs
 - Attention weight matrices W_Q, W_K and $W_V \subseteq \mathbb{R}^{d \times d}$ not partitioned
 - Sizes of Q, K, V **chunks** are $(N/P, d)$

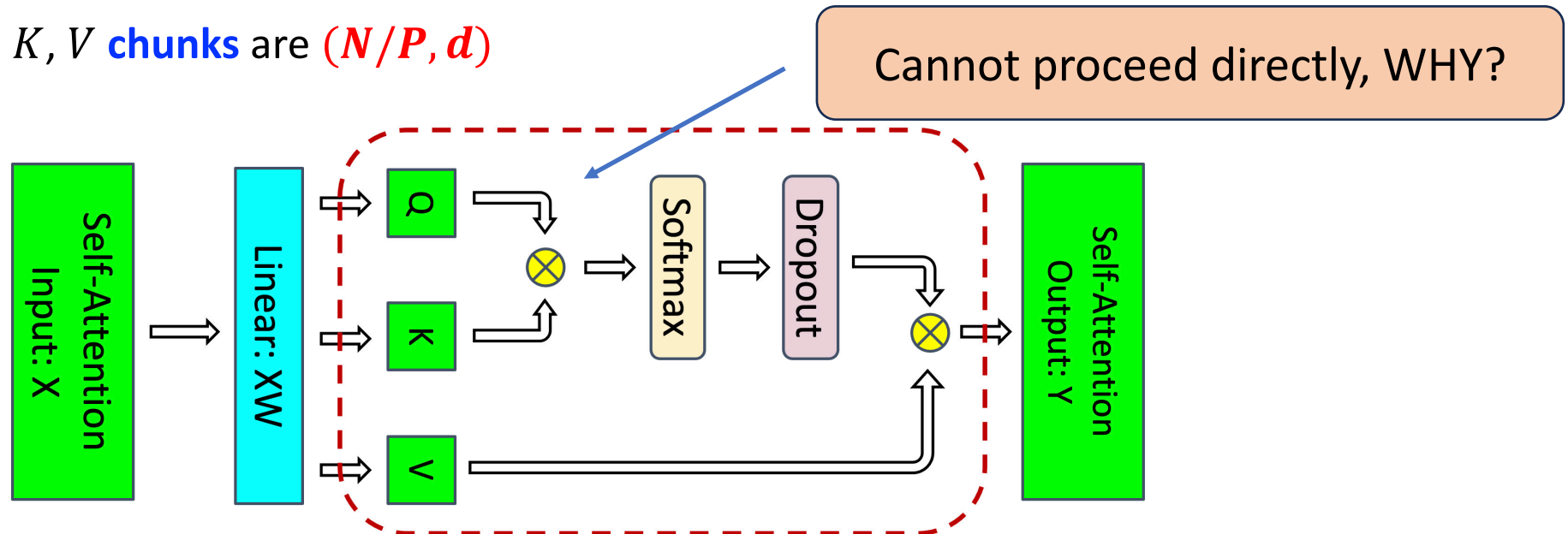

Sequence Parallelism

- DeepSpeed Ulysses Sequence Parallelism

- All-to-All communication

- Before all-to-all, each GPU holds the SEQUENCE CHUNK of **ALL HEADs** (i.e. $(N/P, d)$)
 - After all-to-all, each GPU holds ALL SEQUENCES on a specific HEAD (i.e. $(N, d/P)$)

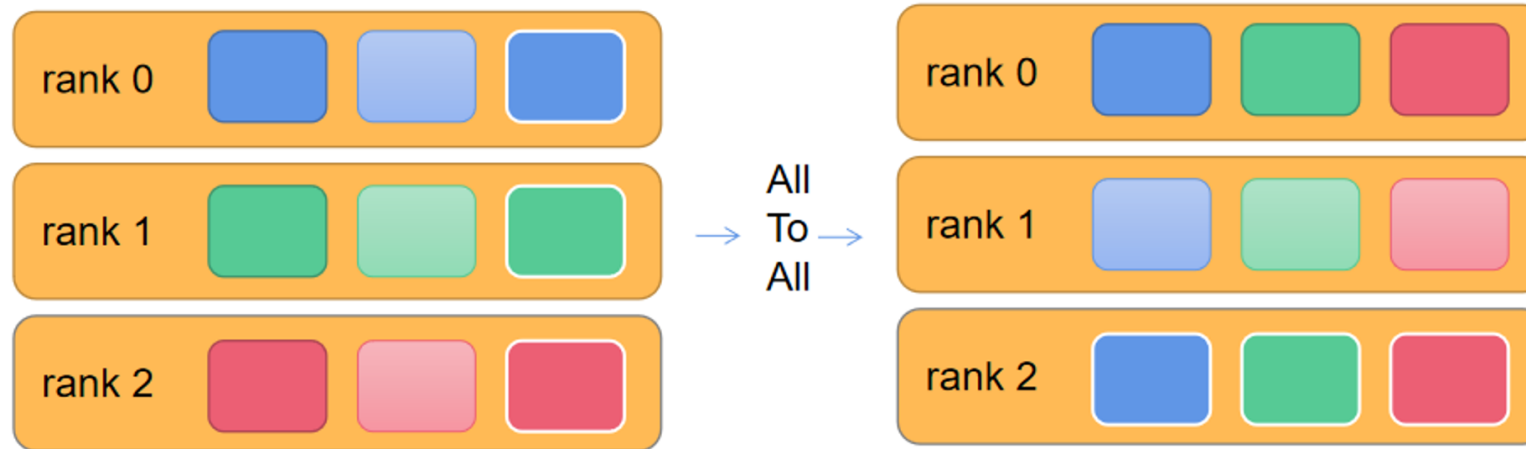

Looks like a transpose operation!

Sequence Parallelism

- DeepSpeed Ulysses Sequence Parallelism
 - All-to-All communication

Multi-head Attention Computation

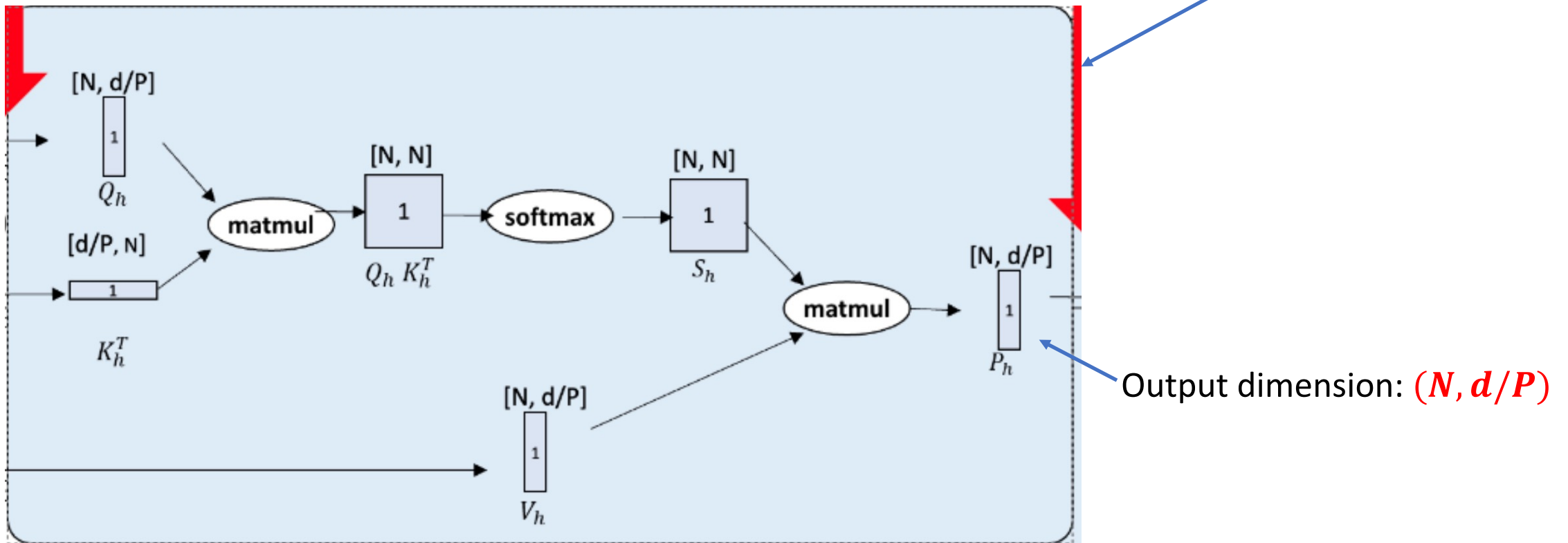

Sequence Parallelism

- DeepSpeed Ulysses Sequence Parallelism

- MLP can compute at each sequence chunk granularity

- DeepSpeed Ulysses backward pass

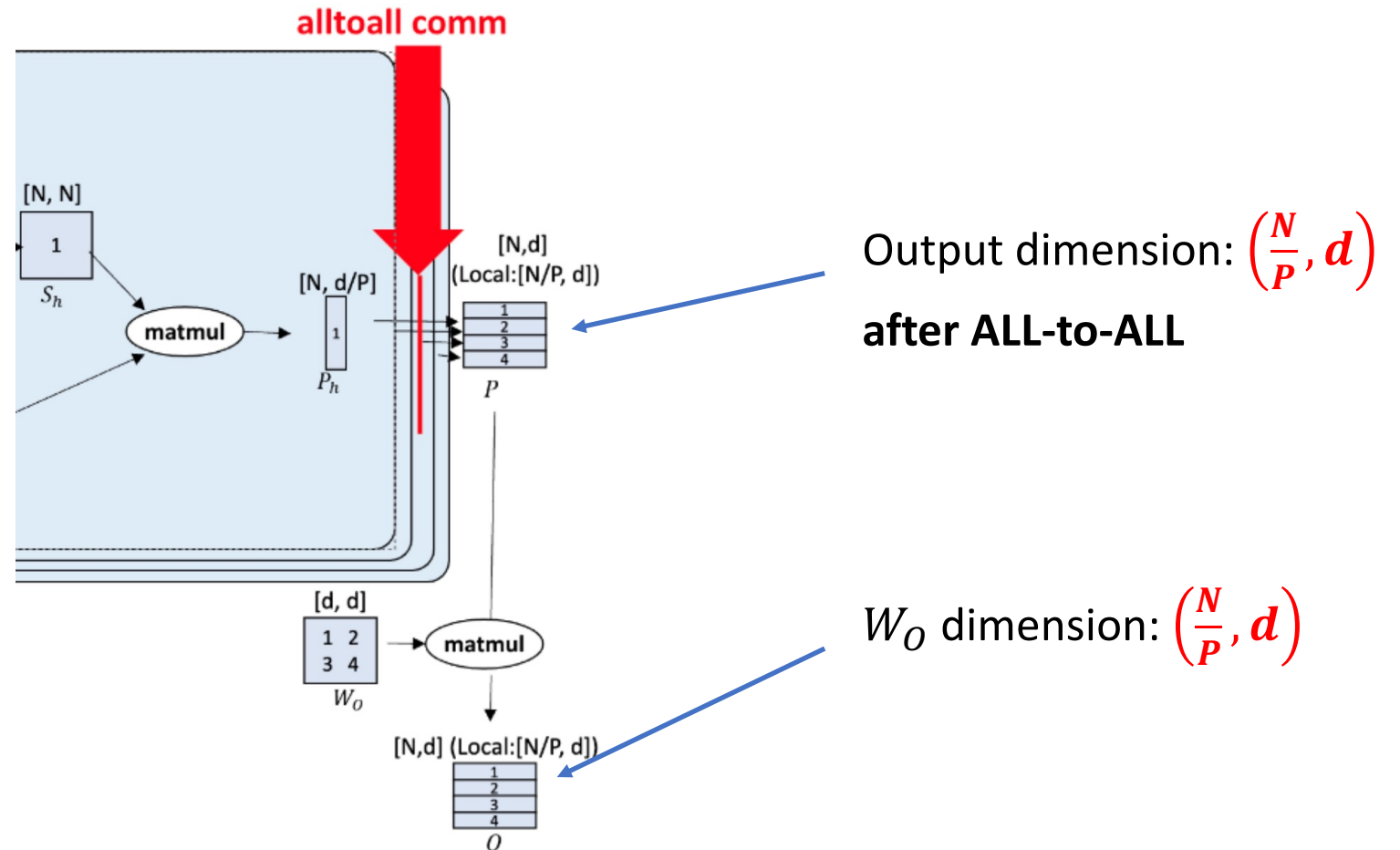

Sequence Parallelism

- DeepSpeed Ulysses Sequence Parallelism: Communication Analysis

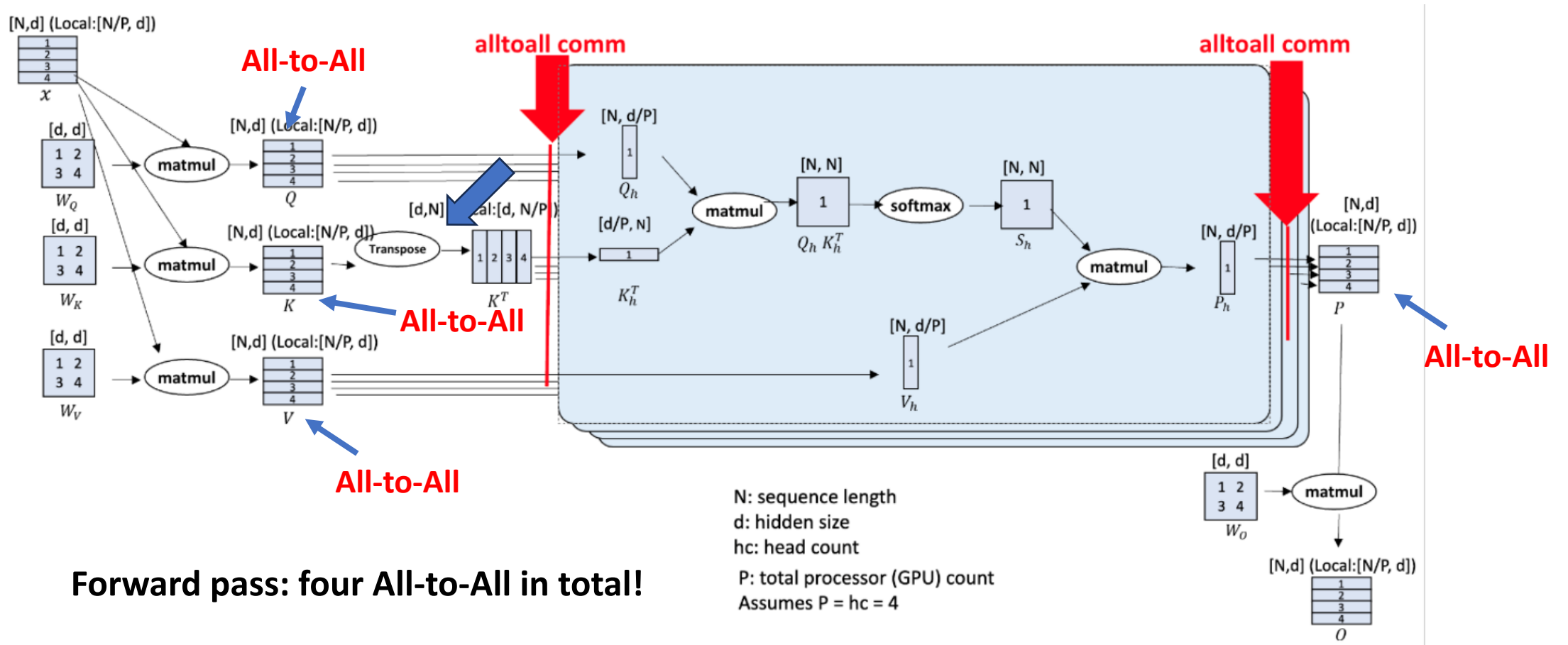

Sequence Parallelism

- DeepSpeed Ulysses Sequence Parallelism: Communication Analysis

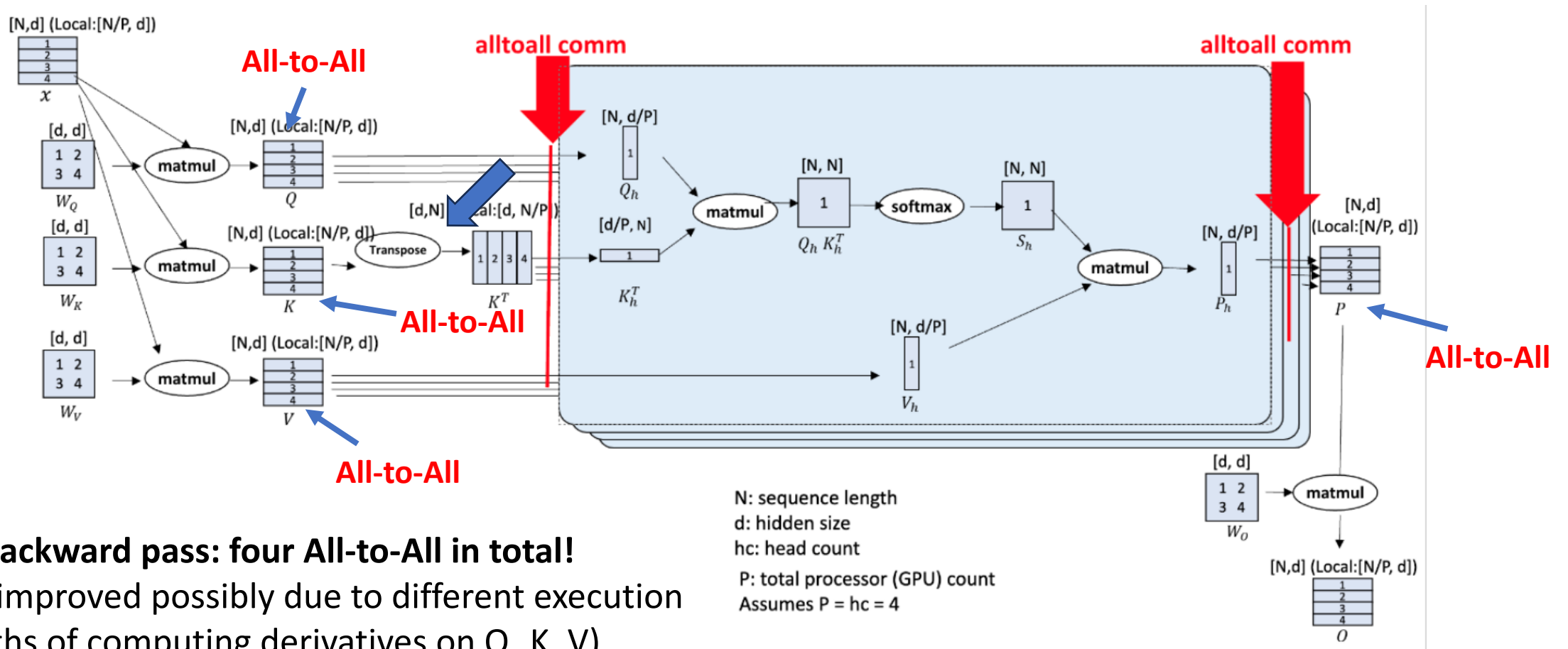

Backward pass: four All-to-All in total!

(Can be improved possibly due to different execution paths of computing derivatives on Q, K, V)

Sequence Parallelism

- DeepSpeed Ulysses versus NVIDIA Megatron
 - Megatron SP **splits attention and MLP layer parameters** by using tensor parallelism, and splits layernorm and dropout inputs accordingly. The computations are carried out on the heads at different GPUs.
 - Ulysses splits attention and MLP by segmenting the input sequences, and the computations are carried out on the heads at different GPUs. **No segmentation** on the attention layer parameters.

(Extended Learning)

Sequence Parallelism

- DeepSpeed Ulysses versus NVIDIA Megatron

	Attention	MLP
Megatron-LM (combined with TP)	$4 N d$ Forward: ReduceScatter + AllGather, Backward: ReduceScatter + AllGather	$4 N d$ Forward: ReduceScatter + AllGather, Backward: ReduceScatter + AllGather
DeepSpeed Ulysses	$8 N d/P$ Forward: 4 All-to-All, Backward: 4 All-to-All	0 MLP is element-wise, naturally fitting SP

(Extended Learning)

Sequence Parallelism

- DeepSpeed Ulysses versus NVIDIA Megatron

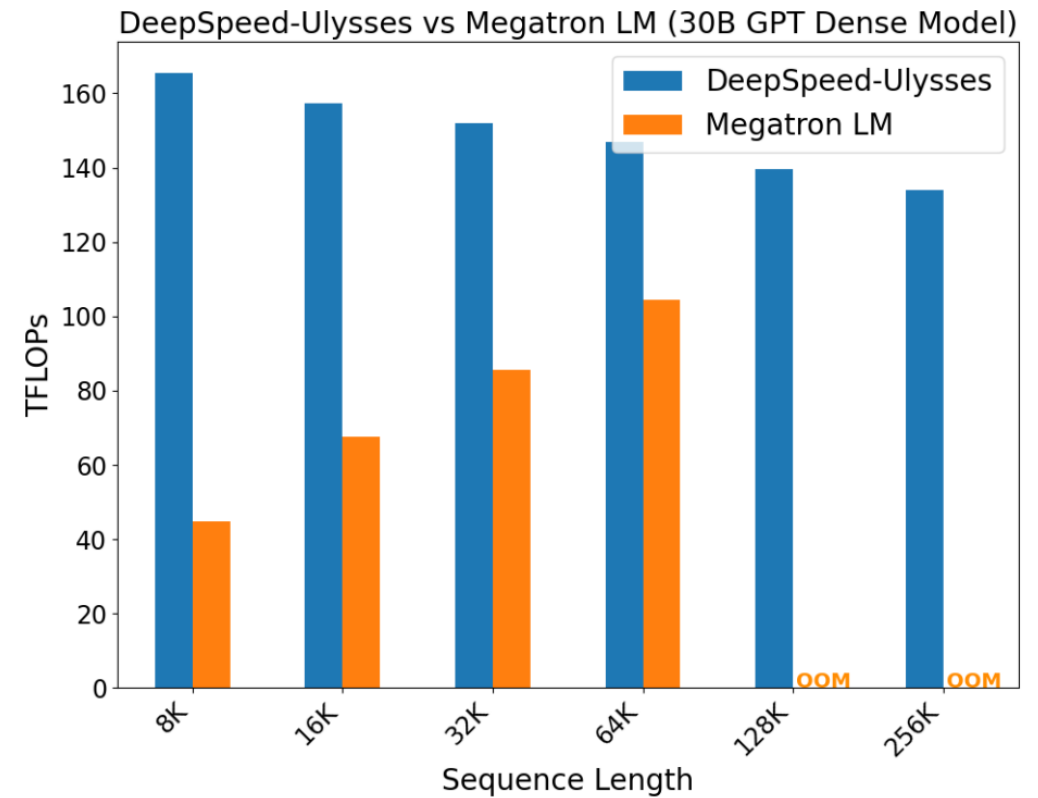
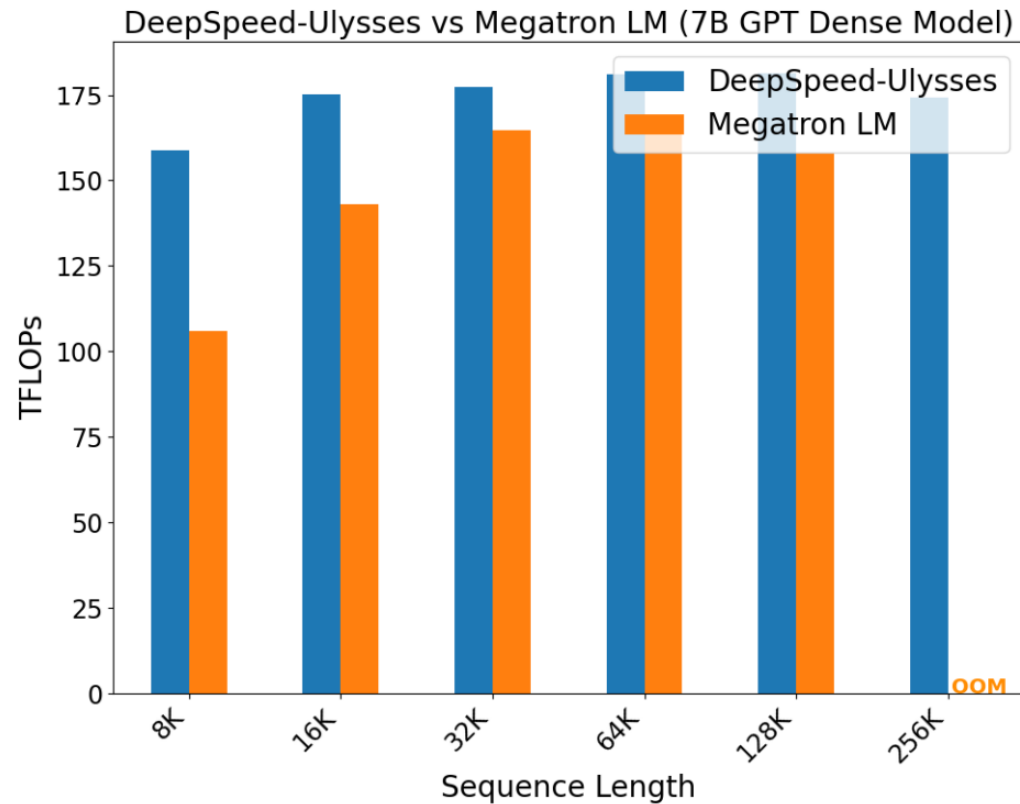

Sequence Parallelism



- DeepSpeed Ulysses versus NVIDIA Megatron
 - $N = 1\text{M}$ tokens, $d = 4096$, $P = 128$, FP16
 - Megatron: $8 \times N \times d = 8 \times 1\text{e}6 \times 4096 \times 2 = 65.536$ GB
 - Ulysses: $8 \times N \times d / P = 65.536 \text{ GB} / 128 = 0.512$ GB

“Ulysses reduces communication volume by eliminating All-Gather in MLP and using All-to-All only in attention, achieving near-linear scaling for sequence lengths up to 1M.”

“Megatron-LM sequence parallelism incurs a communication volume per link of $4Nh$ which is P times larger than that for DeepSpeed sequence parallelism.”

Sequence Parallelism

- Colossal AI Sequence Parallelism

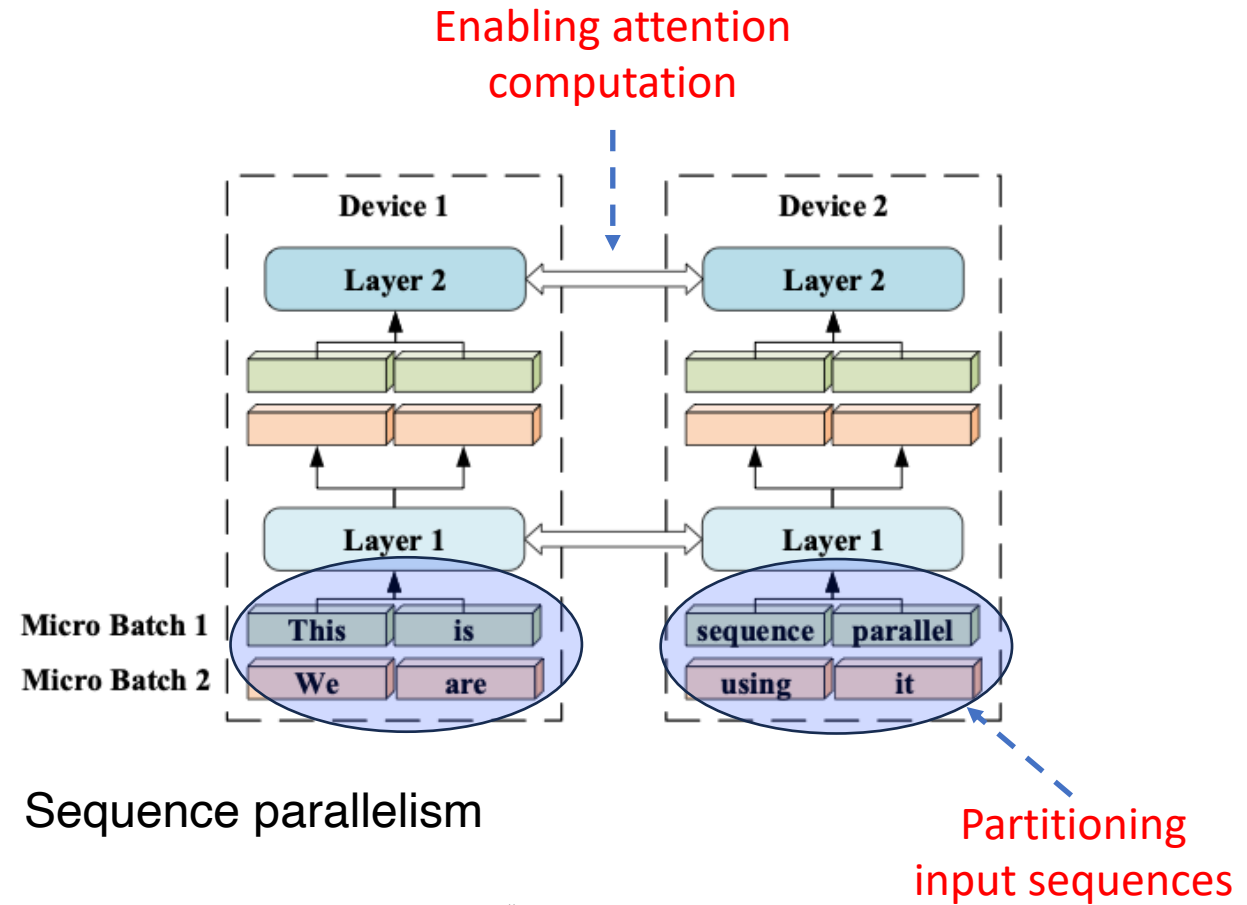
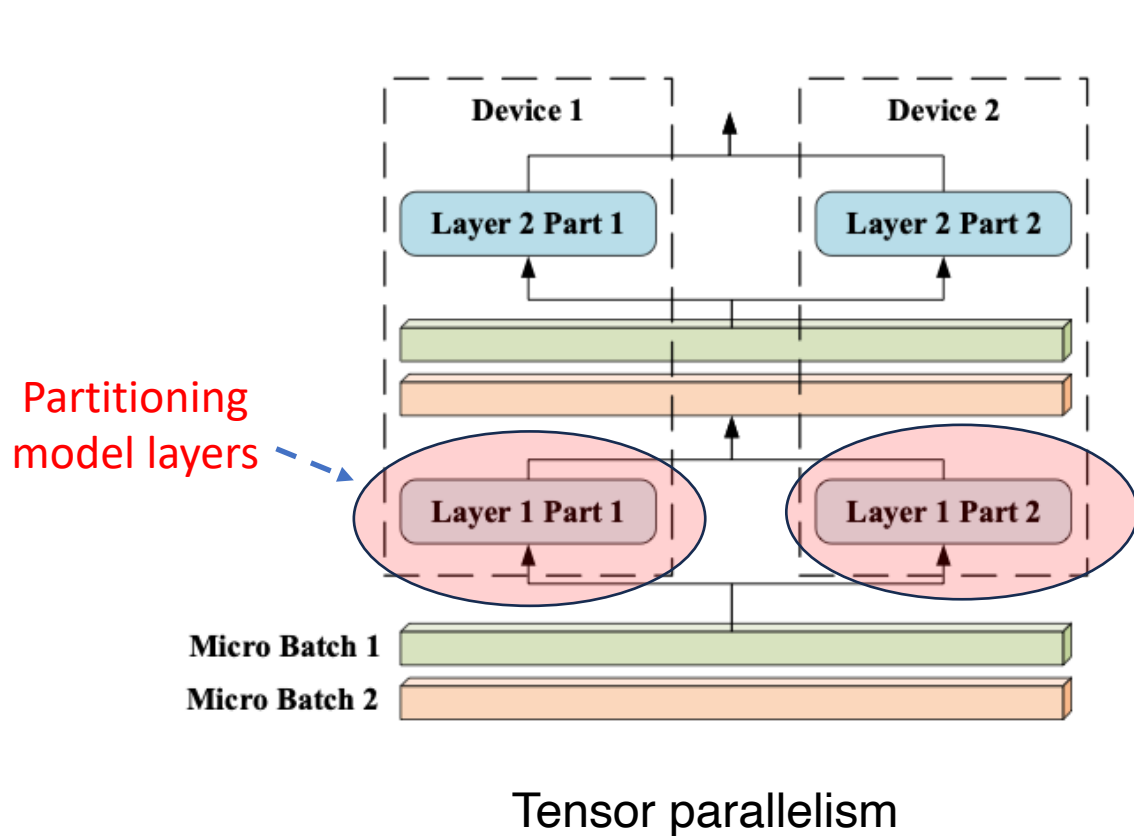

(Extended Learning)

Sequence Parallelism

- Colossal AI Sequence Parallelism
 - Q, K, V partitioned on the **sequence**
 - Computing attention scores need full Q, K, V on all tokens, in which communication is inevitable
 - **Ring Attention** adopted in Colossal-AI

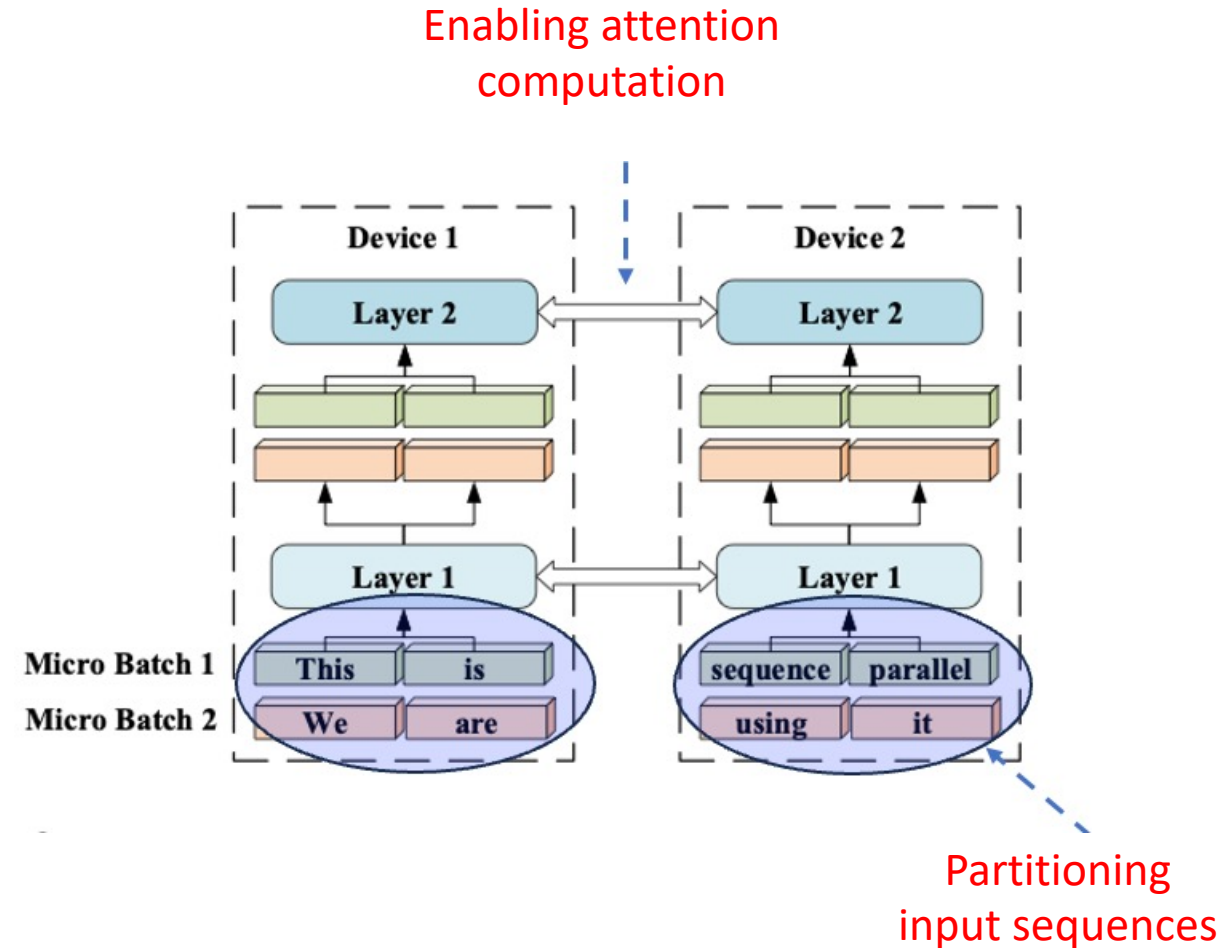

Sequence Parallelism

- Colossal AI Sequence Parallelism

- Convoluted with Attention mechanism (without diving into algorithmic details)

Step 1: for each Q_i , compute attention score by feeding K_j and V_j , and obtain O_{ij}

Step 2: for each K_j and V_j , repeat Step 1 and update O_{ij} , and eventually obtain O_i

Step 3: change Q_i to Q_{i+1} , repeat Step 1 and Step 2 until Q_C

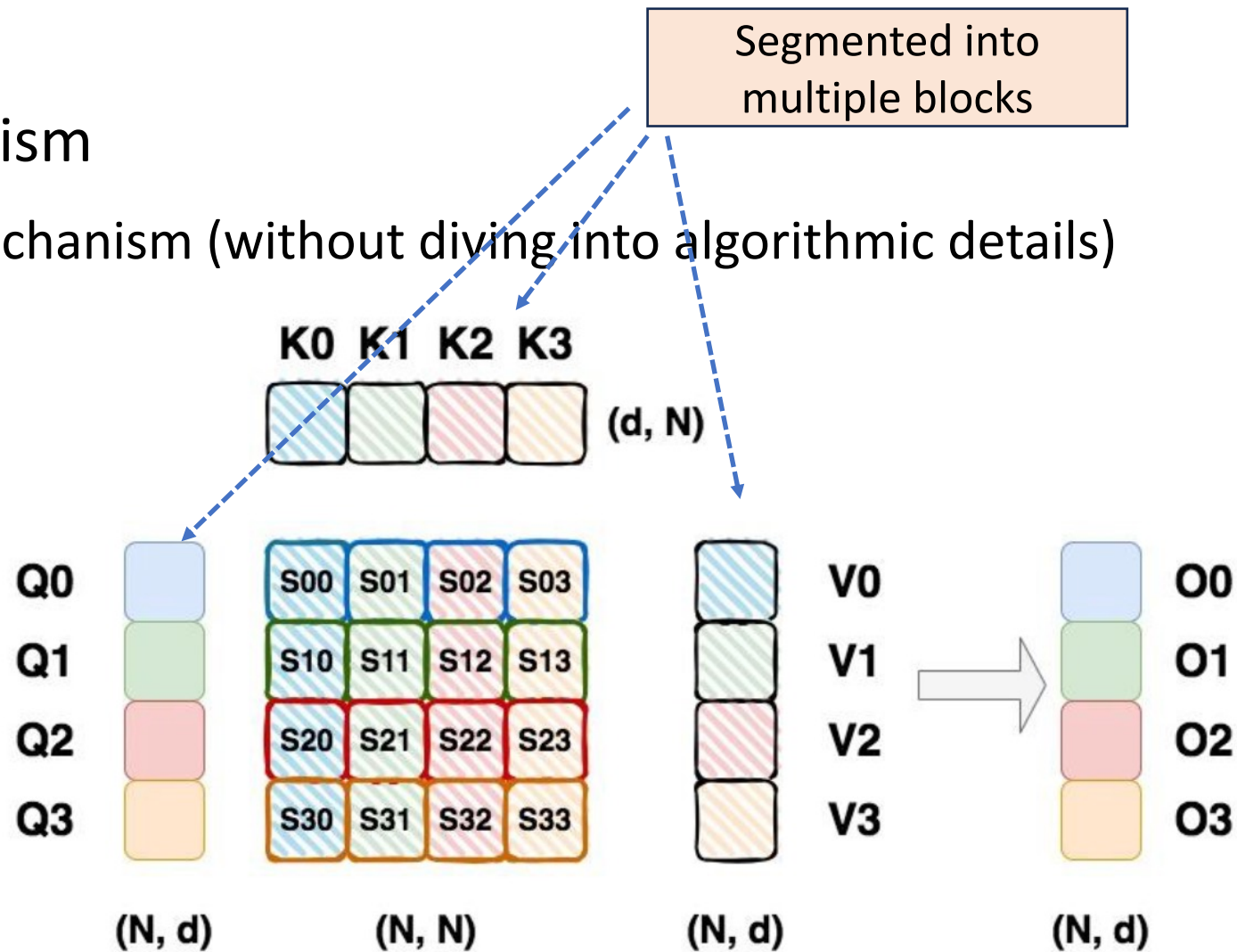

(Extended Learning)

Sequence Parallelism

Mathematical deduction shows that S_{00} , S_{01} , S_{02} , and S_{03} can be computed in an **arbitrary order!**

- Colossal AI Sequence Parallelism

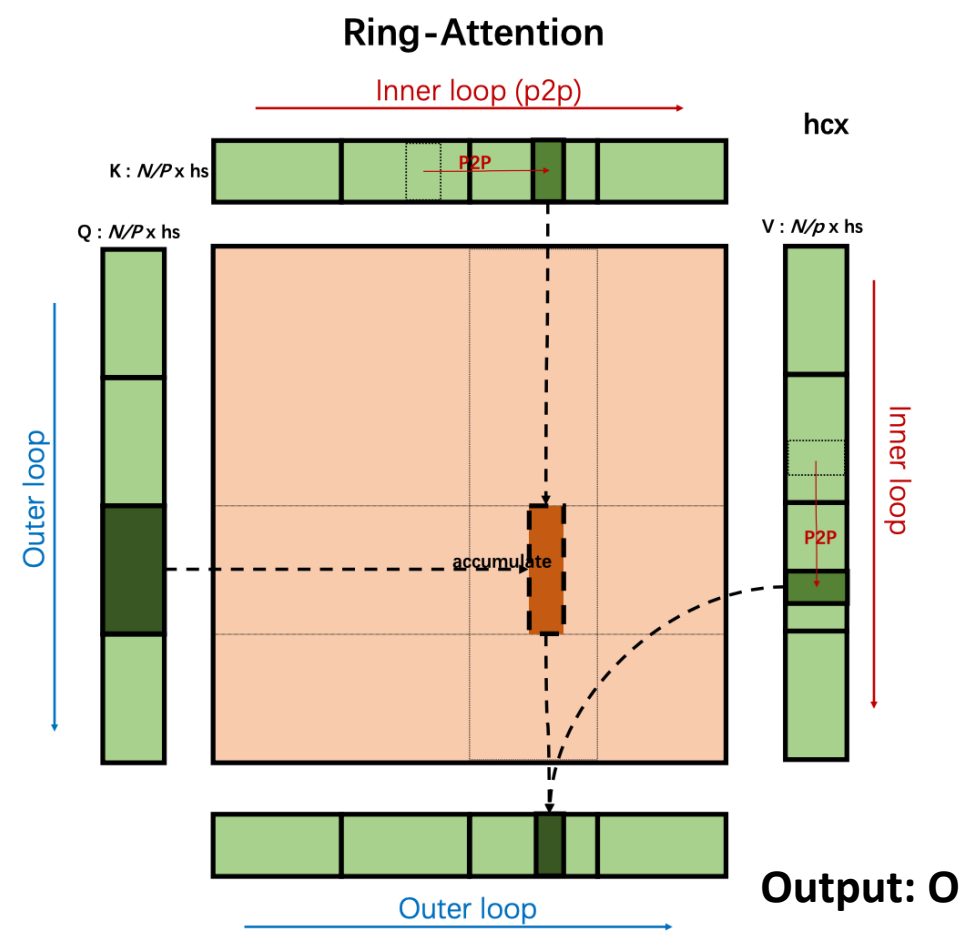
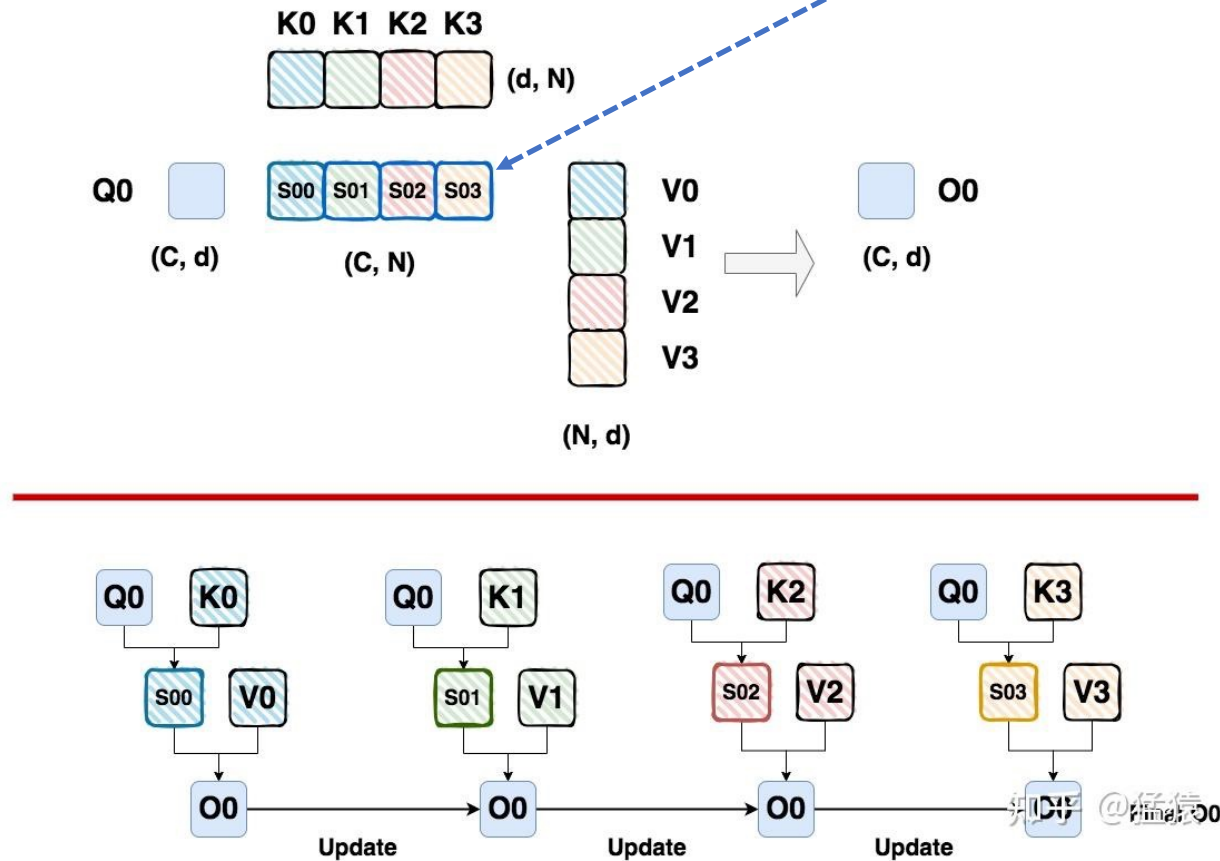

(Extended Learning)

Sequence Parallelism

- Colossal AI Sequence Parallelism

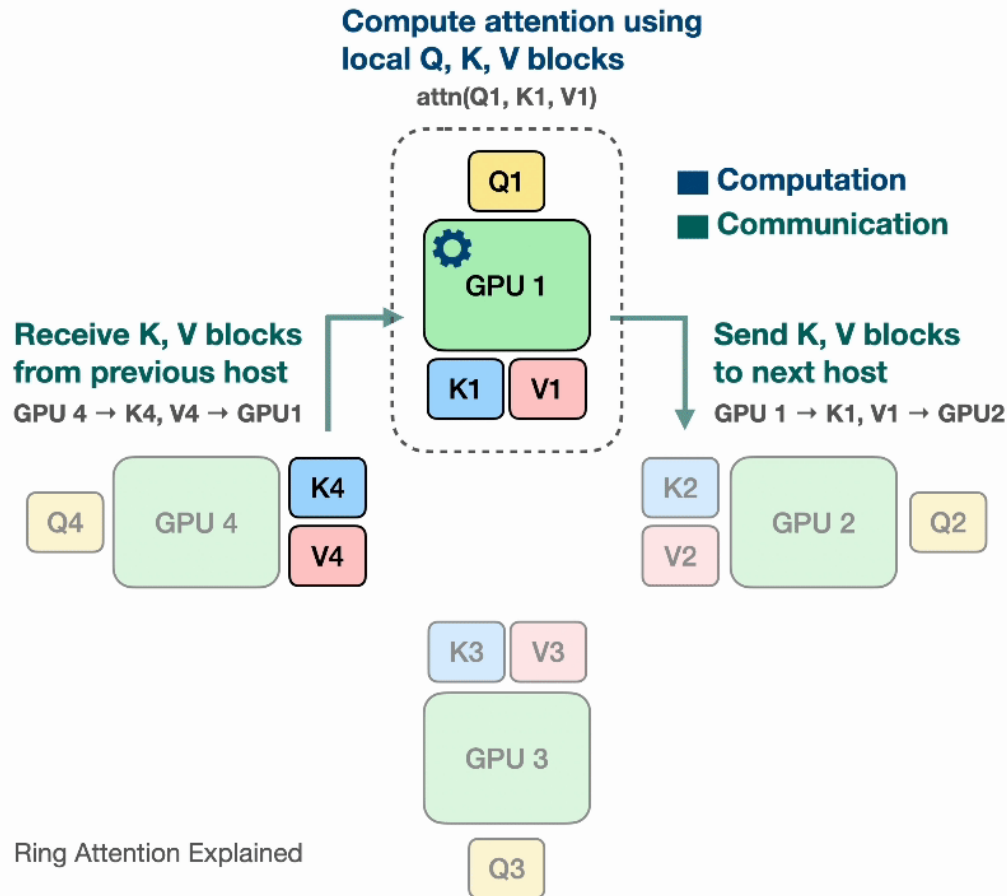

Step 1: GPU1 computes $O1$ using $Q1$, $K1$ and $V1$ (other GPUs do the same thing)

Step 2: GPU1 sends $K1$ and $V1$ to GPU2, and receives $K4$ and $V4$ from GPU4; compute and update $O1$ using $Q1$, $K4$ and $V4$

Step 3: GPU1 sends $K4$ and $V4$ to GPU2, and receives $K3$ and $V3$ from GPU4; compute and update $O1$ using $Q1$, $K3$ and $V3$

Step 4: GPU1 sends $K3$ and $V3$ to GPU2, and receives $K2$ and $V2$ from GPU4; compute and update $O1$ using $Q1$, $K2$ and $V2$

The network communications are illustrated by the blinking arrows.

From <https://coconut-mode.com/posts/ring-attention/>

(Extended Learning)

Sequence Parallelism

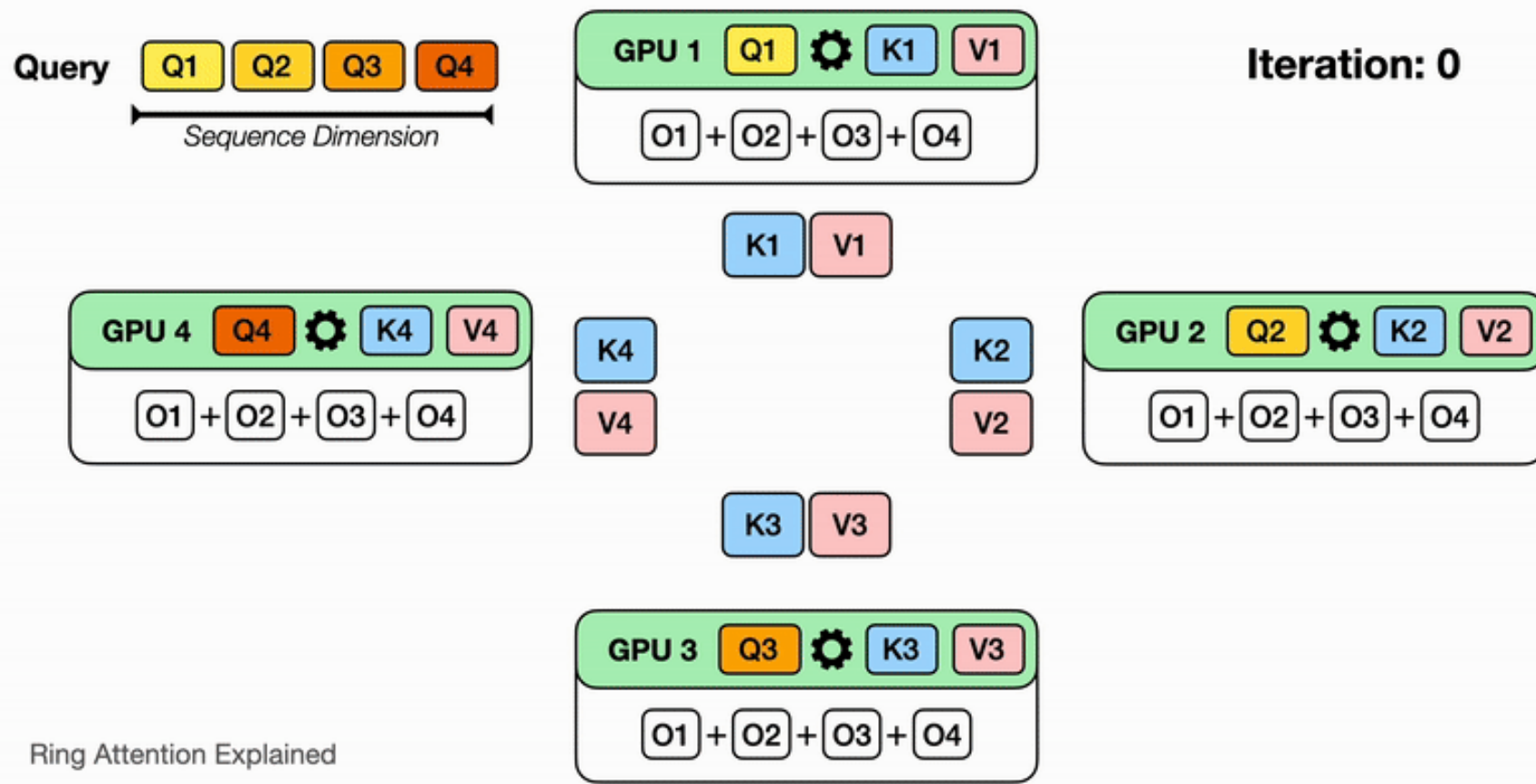

Illustrate for N devices, it will take N iterations to finish the whole output computation. Watch for each iteration on each device, different partial sum of the output is computed with the K, V block it currently has, and it eventually sees all the K, V blocks and has all the partial sum for the output!

Sequence Parallelism

d : hidden dimension
 c : sequence length after slicing

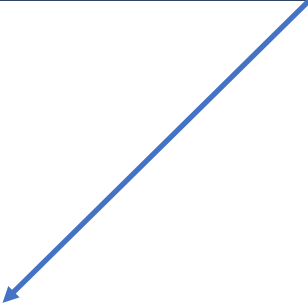

- Colossal AI Sequence Parallelism

- Memory Complexity

- Storing current K and V blocks (in FP16) needs $2dc$ floats or $4dc$ Bytes
 - Receiving new K and V blocks needs $2dc$ floats or $4dc$ Bytes
 - Storing Q_i block needs $2dc$ Bytes
 - Computing the output needs at least $2dc$ Bytes
 - In total at least $12dc$ Bytes, where c is the chunk size

- Communication Complexity

- Each step sends $2dc$ floats or $4dc$ Bytes, and the total number of rotations is around $\frac{S}{c}$
 - At each inner loop a GPU sends $4sd$ Bytes, and the outer loop has p rounds
 - Total communication load is around $O(sdp)$, which is much higher than Megatron and Ulysses

Sequence Parallelism

- Recap
 - Megatron CP: sharding weights and some inputs on the hidden dimension
 - Ulysses CP: sharding input token sequence
 - Ring Attention CP: letting KV blocks flow on the ring

Thanks!

